



Variable Frequency Intelligent Controller for Vibratory Feeder



**SDVC34-UR-US (10AMP)
SDVC34-XU-US (15AMP)**

Instruction Manual

Preface

This instruction book includes detailed steps and explanations of installation, parameter settings, mode settings and troubleshooting of the control. Please read this instruction book carefully before operating the control.

This instruction book applies to the following models:

Variable Frequency Intelligent Controller for Vibratory Feeder
SDVC34-UR-US:10A Output Current
Variable Frequency Intelligent Controller for Vibratory Feeder
SDVC34-XU-US:15A Output Current

Notice

- Never wire control while control is hot. Don't touch power sockets or connectors to avoid electrical shock.
- Never connect controller to 380V AC power.
- Never switch the input power by cutting off power supply through a relay, a PLC or other devices. Output of the controller may be turned on/off via C-Ports or E-Ports.
- Never operate the controller beyond its designed limitations.
- Operate the controller in accordance with this instruction book. We will not assume any civil or criminal liability if the equipment damage or personal injury is caused by improper operation.



Never open the controller shell to avoid shock. Contact Bryant Control if controller breaks down.

Operating Environment

Operating Environment

Please follow the instructions below to ensure better performance and longer lifetime of the controller

- Well-ventilated environment
- Firmly fixed to avoid self vibration
- Operate within the temperature range of 0 °C to 40 °C
- Keep away from droplets, steam, dust and especially oily dust
- Keep away from corrosive or flammable gas and liquid
- Keep away from floating dust and metal particles
- Keep away from electromagnetic interference
- For use at altitude 2000m or lower

Contents

Chapter I Features	1
Chapter II Installation Guide Chapter	2
III Components Descriptions	5
3.1 Descriptions of the Indicators	5
3.2 Descriptions of Signal Control Ports	5
3.3 Descriptions of the Buttons	6
3.4 Descriptions of I/O Interface and Accessories	6
Chapter IV Parameter Adjustment	7
4.1 Common Parameters	7
4.2 Basic Parameters	7
4.3 Advanced Parameters	8
4.4 Auto/Sync Parameters	10
Chapter V Parameter Explanation	11
5.1 Explanation of Standby/Basic Parameters	11
5.2 Explanation of Advanced Parameters	12
5.3 Explanation of Auto/Sync Parameters	15
Chapter VI Operating Modes	18
6.1 Manual Mode	18
6.2 Auto Mode	20
6.3 Semi-Auto Mode	22
6.4 Sync Mode	24
Chapter VII Signal Control	30
7.1 C Port and E Port ON/OFF Control	30
7.2 C Ports and E Ports Logical Relation	37
7.3 Common Parameters of C Ports and E Ports	39
7.4 Remote Speed Control	42
7.5 Storage and Output of Preset Speeds	44
7.6 RS485 Communication	45
7.7 24V DC Control Output	46
7.8 Controlling Alarm Signal	47
7.9 Save and Restore Parameter Settings	48
Chapter VIII Security Functions	49
8.1 Automatic Voltage Regulation	49
8.2 Short-Circuit Protection	49
8.3 Overcurrent Protection	49
8.4 Overheat Protection	49
8.5 Overload Protection	49
8.6 Overvoltage Protection	49
Appendix	50
Appendix A: Dimensions	50
Appendix B: Electrical Specification	51
Appendix C: Troubleshooting Suggestions and Error Explanations	52
Appendix D: Controller Reset	53

Chapter I Features

The controller is specially designed for controlling vibratory feeders in automation systems. This control utilizes the latest electronic technologies with the following features:

Auto FM: Automatic output frequency modulation in real time to ensure the vibratory feeder will always work at its best vibration frequency.

Auto Constant Speed Control: Automatic output voltage adjustment in real time to ensure constant preset feed speed regardless of weight change from the feed material in the vibratory feeder.

Auto Frequency Measuring: Automatically measure and output the best vibration frequency of the vibratory feeder.

Automatic Voltage Regulation: Eliminate both feed speed variation caused by input voltage fluctuation and cross-talk caused by industrial AC frequency.

Waveform Sync: Sync output waveform of the slave controllers with that of the master controller to the same frequency and phase to avoid cross-talk.

Remote ON/OFF Control: The controller has 2 groups of ON/OFF control ports. Switch sensor or PLC can be connected to them to turn on/off the controller. Soft Startup Time, ON Delay Off Delay and Logical Relation of the ON/OFF Control can also be set.

Automatic Switch Sensor Type Recognition: The controller can recognize and adapt to both NPN and PNP type switch sensors.

Soft Startup: In order to avoid sudden shock to the feed material and vibratory feeder, the controller can gently increase output voltage/feed speed from 0 to the preset value upon startup.

Preset Speeds: 4 preset feed speeds can be stored and output by external short-circuit signal.

Acceleration: Maximum output voltage value of the controller can be increased up to 150% of the input voltage value.

Max Adjustable Output Voltage: Max Adjustable Output Voltage can be preset to protect the vibratory feeder from damage caused by high voltage.

Waveform Index: Users can balance efficiency and maximum power by adjusting this parameter.

Remote Speed Control: Output Voltage/Feed Speed of the controller can be adjusted remotely by an external potentiometer, a PLC, or a 1-5V/4-20mA DC signal.

24V DC Control Output: The controller can output 24V DC power associated with logical relation setting of the ON/OFF Control to drive a solenoid, an electrical relay or other external devices.

Control Panel Lock: Lock all buttons on the control panel by pressing the ON/OFF button and hold for 2 seconds to prevent misoperation.

Parameter Lock: Lock all parameters except Output Voltage/Feed Speed by self defined password to prevent unauthorized operation.

Controller Reset: Reset all parameters of the controller to factory defaults.

RS485 Communication: All parameters of the controller can be adjusted via Rs485 communication ports.

Chapter II Installation Guide

Step One:

Open the packing box and check the controller and all accessories.

Step Two:

Connect the wiring terminals of the Output Power Cable to the vibrator's electromagnetic coil.

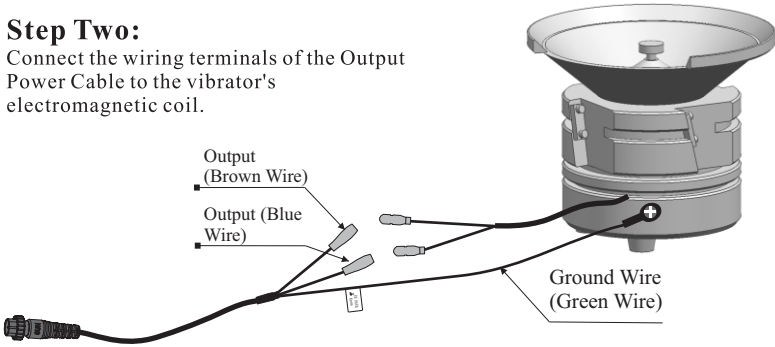

Notice

Make sure the vibrator's electromagnetic coils are connected to the live wire and neutral wire of the Output Power Cable and the shell feeder is reliably grounded, otherwise serious accidents may occur.

Step Three:

Connect the coil to the output power cable on the control.

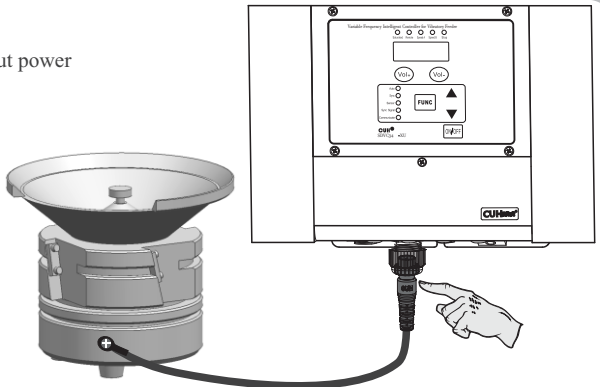

Step Four:

Connect the power cord to the control unit.

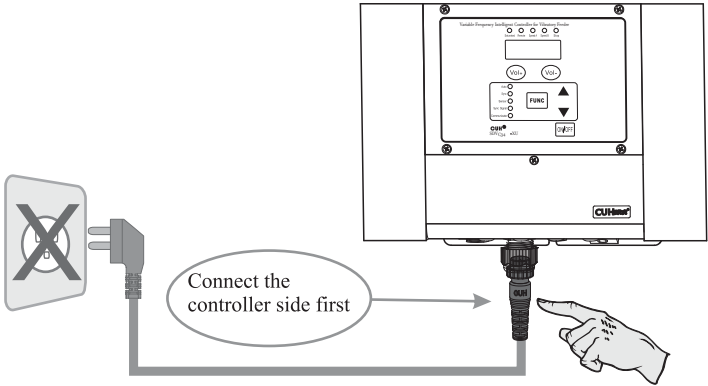

Step Five:

Connect the Input Power Cable plug from the control to an outlet.

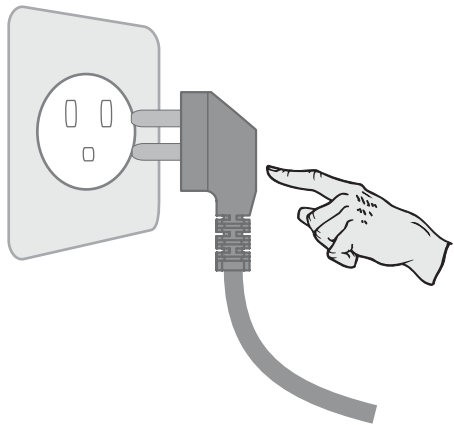

Vibration Sensor Mounting Position

Suggested mounting position:

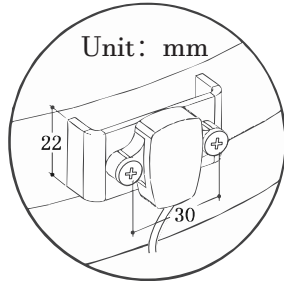
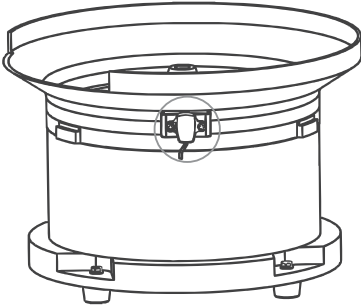
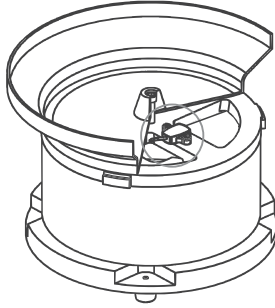
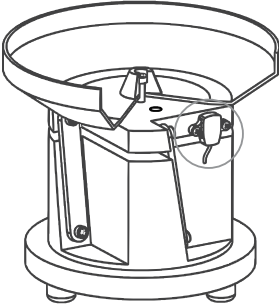

Not suggested mounting position:

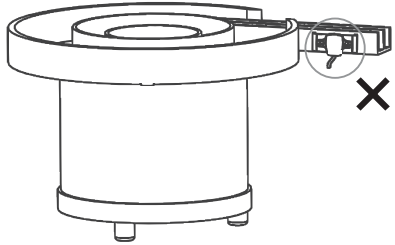
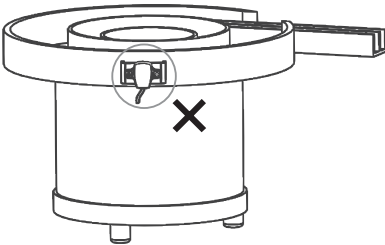

Chapter III Components Descriptions

3.1 Descriptions of the Indicators

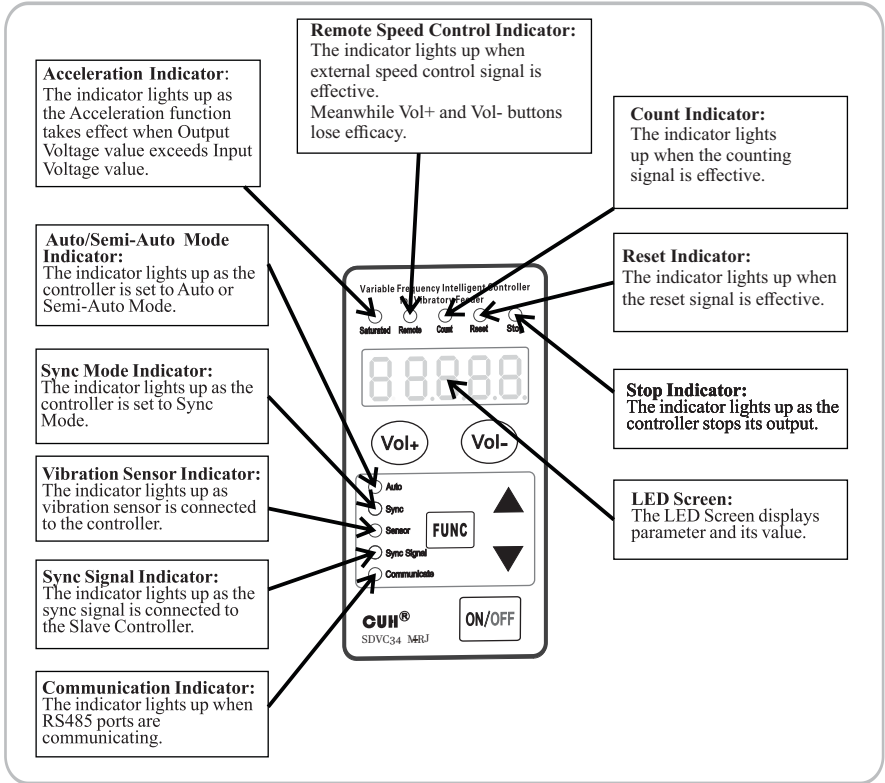

3.2 Descriptions of Signal Control Ports

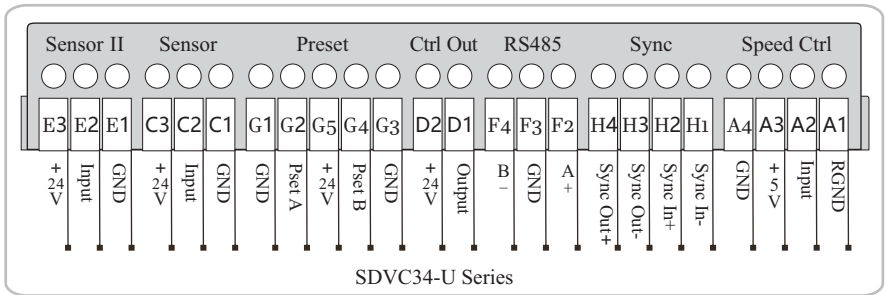

3.3 Descriptions of the Buttons

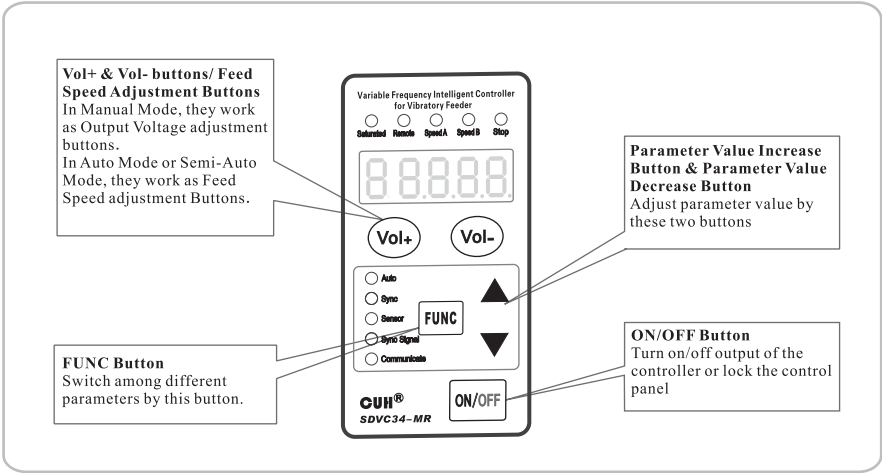

3.4 Descriptions of I/O Interfaces and Accessory

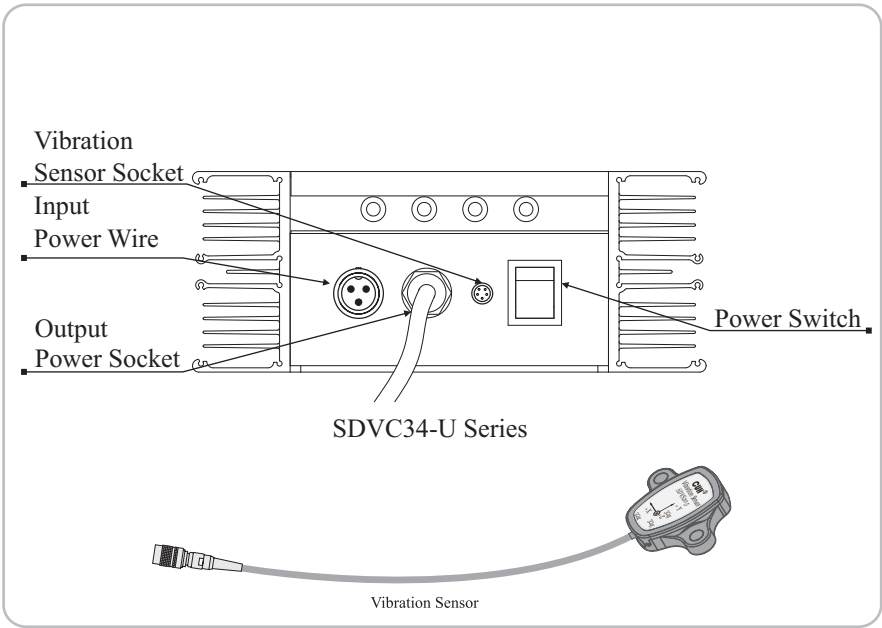

Chapter IV Parameter Adjustment

Parameters of the controller are classified into 4 types according to different adjustment methods: Common Parameters, Basic Parameters, Advanced Parameters and Auto/Sync Parameters.

4.1 Common Parameters

- Press “Vol+” or “Vol-” button to adjust Common Parameters.
- Common Parameters can be adjusted by pressing “Vol+” or “Vol-” button even when any other parameter is displayed on the LED screen. The controller will go back to the previous parameter after adjusting Common Parameters.

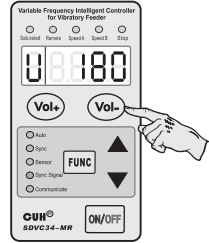

	Definition	Symbol	Range	Default
Standby Parameter	Output Voltage	U	u.~U. V	0
	Feed Speed	R	0~3200	5

4.2 Basic Parameters

- Press and hold “FUNC” button for 2 seconds to enter basic parameters.
- Press “FUNC” button repeatedly to cycle through different parameters.
- Press ▲ or ▼ button to adjust the parameter value.
- Press and hold “FUNC” button for 2 seconds to exit basic parameters

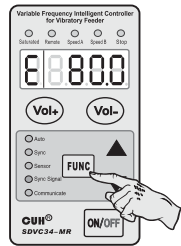

	Definition	Symbol	Range	Default
Basic Parameter Long press [FUNC]	Output Frequency	E	e.~E. Hz	60.0
	Port C On Delay	J	0.0~20 s	0.2
	Port C Off Delay	L	0.0~20 s	0.2
	Soft Startup Time	t	0.0~10.0 s	0.5
	Soft Startup Time	3	If parameter lock password is set screen will display current password	/





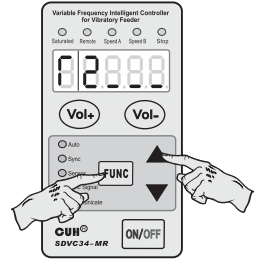















4.3 Advanced Parameters

- Press and hold “FUNC” and ▲ buttons simultaneously for 2 seconds to enter Advanced Parameters.
- Press “FUNC” button repeatedly to cycle through different parameters.
- Press ▲ or ▼ button to adjust the parameter value.
- Press and hold “FUNC” and ▲ buttons simultaneously for 2 seconds to exit Advanced Parameters.



	Definition	Symbol	Range	Default
Advanced Parameter Long press [ESC] and ▲	Port E On Delay	1-8888	0.0~20.0 s	0.0
	Port E Off Delay	L-8888	0.0~20.0 s	0.0
	Port C Logical Relation	r2-8888	--- Positive Logic, -- - Negative Logic	---
	Port E Logical Relation	r7-8888	--- Positive Logic, -- - Negative Logic	---
	24V Ctrl Out Logical Relation	r3-8888	--- Positive Logic, -- - Negative Logic - 7 - Control by alarm signal	---
	Logic Operation of Main Output	r4-8888	--- Positive Logic, -- - Negative Logic	---
	Logic Operation of Ctrl Output	r8-8888	--- Main Logic, -- - The second set of Logic - - - Parameter setting of the second logic set	---
	Switch Sensor Type	rA-8888	Uto, nPn, PnP	Uto
	Logic Relation of Port C and E	n-8888	- - - And - - - or - - - Xor	- - -
	Output Voltage Upper Limit	U-8888	0~250 V	120
	Output Voltage Lower Limit	u-8888	0~240 V	0
	Output Frequency Upper Limit	F-8888	15.0~400.0 Hz	140.0
	Output Frequency Lower Limit	f-8888	5.0~390.0 Hz	45.0

Advanced Parameters Continued →

	Definition	Symbol	Range	Default
Advanced Parameter Long press  and 	Acceleration Index		100~150 %	120
	Waveform Index		0~100	100
	Temperature Display		-20.0~80.0 (°C)	/
	Communication Protocol		ASC, rtu	rtu
	Communication Address		1~31	1
	Communication Baud Rate		0.3~115.2 kbps	9.6
	Parameter Lock Password		0~9999	---
	Power On Status		--- Run, --- Stop --- Follow before power off	---
	Software Version		/	/
	Controller Reset		/	/
	Access Password to Saving Setting		 Wrong password alarm  Saving user setting password  Saving factory default settings password Pin set to other values : Wrong password	0
	Ready to Save Parameter Settings		 User parameter settings saved  Factory default settings saved  Wrong password alarm	/

4.4 Auto/ Sync Parameters

- Press and hold “FUNC” and ▼ buttons simultaneously for 2 seconds to enter Auto/Sync Parameters.
- Press “FUNC” button repeatedly to cycle through different parameters.
- Press ▲ or ▼ button to adjust the parameter value.
Press and hold “FUNC” and ▼ buttons simultaneously for 2 seconds to exit Auto/Sync Parameters.

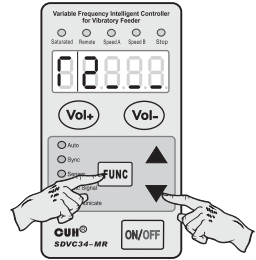

	Definition	Symbol	Range	Default
Auto/Sync Parameter Long press [FUNC] and ▼	Centre Frequency	F 0000	e.~E. Hz	120.0
	Max Offset in Auto FM	n 0000	0.0~180.0 Hz	30.0
	Output Voltage Adjustment Method	fS 0000	- - - Auto, - - Manual	- - -
	Output Frequency Adjustment Method	f6 0000	Auto, - - Manual, - - - Sync	- - -
	Output Frequency Auto Adjustment Index	IF 0000	0~200	20
	Amplitude Auto Adjustment Index	PA 0000	0~999	60
	Amplitude Auto Adjustment Index	IA 0000	0~999	50
	Feed Speed Display	H 0000	0~H	0
	Output Voltage Display	G 0000	u.~U. V	0
	Lower Limit of Voltage	GL 0000	u.~U. V	- - -
	Lower Limit of Frequency	e 0000	e.~E. Hz	- - -
	Max Amplitude Index	P 0000	0~500	500
	Max Adjustable Feed Speed	H 0000	0~3200	1500
	Phase Difference	P 0000	-180~180 °	0
	Max Output Voltage in Auto	b 0000	0~260 V	50
	Frequency Measuring Process	SP 0000	1~5	5
	Frequency Searching Speed	SP 0000	1~5	5
	Feed Speed Min Adjustment Volume	c 0000	1~10	1
	Vibration Sensor Number	f 0000	0, 1, 2, 3, 4, 203, 204, 205, 206	205

Chapter V Parameter Explanations

5.1 Explanation of Standby/Basic Parameters

5.1.1 Output Voltage \mathbb{U}

Output Voltage default is 0V. Use Vol+ or Vol- to increase or decrease \mathbb{U} . Refer to 4.1 Common Parameters for more information.

5.1.2 Feed Speed \mathbb{R}

Feed Speed default is 5V. Use Vol+ or Vol- to increase or decrease \mathbb{R} . Refer to 4.1 Common Parameters for more information.

5.1.3 Output Frequency \mathbb{E}

Output Frequency \mathbb{E} can only be adjusted in manual mode. Default is 60 Hz. Refer to 6.1.2 Output Frequency Parameter \mathbb{E} Adjustment in Manual Mode for more information.

5.1.4 Port C On Delay \mathbb{J}

Port C On Delay default is 0.2 seconds. The range is 0~20 seconds. Refer to 7.1.2.1 C Port ON/OFF Delay for more information.

5.1.5 Port C Off Delay \mathbb{L}

Port C Off Delay default is 0.2 seconds. The range is 0~20 seconds. Refer to 7.1.2.1 C Port ON/OFF Delay for more information.

5.1.6 Soft Startup Time \mathbb{E}

Soft Startup Time can be set from 0-10 seconds with its default set to 0.5 seconds. The higher this value is set, the more gradually the control will reach the set Output Voltage \mathbb{U} /Feed Speed \mathbb{R} . Refer to 4.2 Basic Parameters for more information.

5.2 Explanation of Advanced Parameters

5.2.1 Port E On Delay \downarrow -

Port E On Delay default is 0 seconds. The range is 0~20 seconds. Refer to 7.1.2.2 E Port ON/OFF Delay for more information.

5.2.2 Port E Off Delay \downarrow -

Port E Off Delay default is 0 seconds. The range is 0~20 seconds. Refer to 7.1.2.2 E Port ON/OFF Delay for more information.

5.2.3 Port C Logical Relation $\uparrow \downarrow$

By default controller runs when no signal is received from C Port. Parameter $\uparrow \downarrow$ can be adjusted so that the control will stop when no signal is received from C Port. Refer to 7.2.1 C Port ON/OFF Control Logical Relation Parameter $\uparrow \downarrow$ for more information.

5.2.4 Port E Logical Relation $\uparrow \uparrow$

By default the controller runs when no signal is received from E Port. Parameter $\uparrow \uparrow$ can be adjusted so that the control will stop when no signal is received from E Port. Refer to 7.2.2 E Port ON/OFF Control Logical Relation Parameter $\uparrow \uparrow$ for more information.

5.2.5 24V Control Out Logical Relation $\uparrow \downarrow$

By default 24V DC control output will be on when output of the control is on. This Parameter can be changed so 24V DC control output will be off when output of the control is on. This Parameter can also be changed so that 24V DC control output will be on when conditions for alarm signal are met. Refer to 7.7.2 Logic Relation of the 24V DC Control Output and 7.8 Controlling Alarm Signal for more information.

5.2.6 Logic Operation of Main Output $\uparrow \downarrow$

This parameter will control whether or not the 24V DC control output is correlated to the control ON/OFF. Refer to 7.3.3 Whether or not output of the controller is controlled by ON/OFF control signal parameter $\uparrow \downarrow$ for more information.

5.2.7 Logic Operation of Control Output $\uparrow \downarrow$

$\uparrow \downarrow$ controls whether or not the port delay affects the main output or the ctrl output. $\uparrow \downarrow$ main logic ($_ _$) is for controlling the main output with port signals, delays and logic relationships. The second set of logic ($_ _$) means that the main output is only controlled by the panel and is unrelated to the port signals. Refer to 7.3.4 D Port Ctrl Out Logic Relation for more information.

5.2.8 Switch Sensor Type $\uparrow \downarrow$

By default this parameter will automatically recognize NPN and PNP. This parameter can be manually adjusted. Refer to 7.3.2 Switch Sensor Type Parameter $\uparrow \downarrow$.

5.2.9 Logic relation of Port C and E $\uparrow \downarrow$

This parameter determines whether or not the control will run based on the conditions of the C Ports and E Ports. Refer to 7.3.1 Logical Relation Parameter $\uparrow \downarrow$ of C Ports and E Ports for more information.

5.2.10 Output Voltage Upper Limit \downarrow

Output Voltage Range is 0 to 250(V). Parameter \downarrow restricts Maximum Output Voltage to designated value to protect the vibratory feeder from high voltage caused by misoperation. Remote Speed Control voltage is also affected by this Parameter. Refer to 4.3 Advanced Parameters for more information.

5.2 Explanation of Advanced Parameters

5.2.11 Output Voltage Lower Limit \mathcal{U} .

Output Voltage Range is 0 to 250(V). Parameter \mathcal{U} restricts Minimum Output Voltage to designated value to protect the vibratory feeder from low voltage caused by misoperation. Remote Speed Control voltage is also affected by this Parameter. Refer to 4.3 Advanced Parameters for more information.

5.2.12 Output Frequency Upper Limit \mathcal{E} .

Output Frequency Range is 15 to 400(Hz). Parameter \mathcal{E} restricts Maximum Output Frequency to designated value to protect the vibratory feeder from misoperation. Refer to 4.3 Advanced Parameters for more information.

5.2.13 Output Frequency Lower Limit \mathcal{E} .

Output Frequency Range is 5 to 390(Hz). Parameter \mathcal{E} restricts Minimum Output Frequency to designated value to protect the vibratory feeder from misoperation. Refer to 4.3 Advanced Parameters for more information.

5.2.14 Acceleration Index \mathcal{Y}

Parameter \mathcal{Y} ranges from 100% to 150%. Output Voltage Value can be adjusted higher than Input Voltage Value by setting this parameter. Max Output Voltage still won't exceed Parameter \mathcal{U} .

5.2.15 Waveform Index \mathcal{F}

*Not recommended to adjust. This parameter will automatically adjust itself. Users can weight Max Efficiency and Minimum Noise by adjusting this index.

5.2.16 Temperature Display \mathcal{C}

This Parameter displays the internal temperature of the controller in real time. Non-adjustable.

5.2.17 Communication Protocol \mathcal{P}

For RS485 Communication refer to RS485 Protocol manual.

5.2.18 Communication Address \mathcal{P}

This is the designated communication address for RS485, it can be adjusted between 1 and 32. Refer to 7.6.1 RS485 Communication Address Parameter \mathcal{P} .

5.2.19 Communication Baud Rate \mathcal{C}

The communication Baud Rate has a default of 9.6 kbps. This can be adjusted between 0.3 and 115.2 kbps. Refer to 7.6.2 RS485 Communication Baud Rate Parameter \mathcal{C} .

5.2.20 Parameter Lock Password \mathcal{P} -

This parameter locks all Parameters except for Standby Parameters (Output Voltage/Feed Speed). To set Parameter Lock Password, change --- to desired password (0-999). After setting password, cycle power. When trying to access Basic Parameters, Advanced Parameters and Auto/Sync Parameters the device will now require your set password.

5.2.21 Power On Status \mathcal{F} \mathcal{d}

This parameter will change if the output of the control is ON/OFF when the control is turned on.

5.2 Explanation of Advanced Parameters

5.2.22 Software Version **Ur**

This Parameter displays the current software version of the controller. Non-adjustable.

5.2.23 Controller Reset **88888**

This Parameter is used to reset all other Parameters to factory defaults. Refer to 5.4.3 Restore the Controller to Memory Saved Settings for instructions.

5.2.24 Access Password to Saving Setting **P1 n**

Set pin to **P1.n.5** to set user settings. Set pin to **P1.n.55** to restore to factory default setting. Refer to 7.9 Save and Restore Parameter Settings for more information.

5.2.25 Ready to Save Parameter Settings **SAVE**

Use this parameter to save **P1.n.5** and **P1.n.55** to the memory of the control. Refer to 7.9 Save and Restore Parameter Settings for more information.

5.3 Explanation of Auto/Sync Parameters

(Concerning adjustment method, value range and unit of Auto/Sync Parameters please refer to section 4.4)

5.3.1 Output Voltage Adjustment Method Parameter $f5$

When Parameter $f5$ is set to $_{-}$, Output Voltage Parameter U will be visible while Parameter R is hidden. Output Voltage Parameter U can be adjusted manually.

When Parameter $f5$ is set to $_{-}$ and Vibration Sensor is connected to the controller Feed Speed Parameter R will be visible while Parameter U is hidden. Output Voltage will be adjusted automatically based on feedback from the Vibration Sensor to ensure constant preset feed speed.

Note:

When the Vibration Sensor is not connected to the controller, even if parameter $f5$ is set to $_{-}$, Parameter U will still be visible and manually adjustable.

5.3.2 Output Frequency Adjustment Method Parameter $f6$

When Parameter $f6$ is set to $_{-}$, Output Frequency Parameter E can be adjusted manually.

When Parameter $f6$ is set to $_{-}$ and the Vibration Sensor is connected to the controller, Output Frequency Parameter E will be adjusted automatically to resonant frequency of the vibratory feeder based on feedback from the Vibration Sensor. Output Frequency can not be adjusted manually.

When Parameter $f6$ is set to $_{-}$ and Sync Signal Wire is connected between Master and Slave Controllers. Output Frequency of the Slave Controller will always be consistent with that of the Master Controller. Output Frequency of the Slave Controller can not be adjusted manually.

Note:

When the Vibration Sensor is not connected to the controller, even if Parameter $f6$ is set to $_{-}$, Output Frequency will still be adjusted manually.

5.3.3 Centre Frequency Parameter F

Centre Frequency should be set around resonant frequency of the vibratory feeder so that the controller can find the best vibration frequency more quickly.

5.3.4 Max Offset in Auto FM Parameter n

Auto FM range is $(F \pm n)$ Hz.

Suggested n value is around 30.0 Hz. If Parameter n is set too large, the vibratory feeder may work at improper vibration frequency. If Parameter n is set too small, flexibility of the vibratory feeder may be affected.

5.3.5 Output Frequency Auto Adjustment Index IF

The Auto FM process is running via PID algorithm. IF is a frequency integration index. The larger Parameter IF is set, and the faster Output Frequency is auto modulated. But too large IF value may cause oscillation of the Output Frequency.

5.3.6 Amplitude Auto Adjustment Index PA

The Controller adjusts Output Voltage automatically via the PID algorithm. PA is a speed ratio index. The larger Parameter PA is set, the faster Output Voltage is auto adjusted. Too large of a PA value may cause oscillation of the Output Voltage.

5.3.7 Amplitude Auto Adjustment Index IA

The controller adjusts Output Voltage automatically via PID algorithm. IA is a speed integration index.

The larger Parameter IA is set, the faster Output Voltage is auto adjusted. Too large of a IA value may cause oscillation of the Output Voltage.

5.3.8 Feed Speed Display Parameter H

Parameter H is designed for displaying Feed Speed.

Parameter H is non-adjustable.

5.3.9 Output Voltage Display Parameter G

Parameter G is designed for displaying Output Voltage.

Parameter G is non-adjustable.

5.3.10 Lower Limit of Voltage GL

Parameter GL sends an alarm signal to port D upon Parameter G dropping below specified value of GL . Accelerometer must be attached. Parameter $f3$ needs to be set to $-7-$ and Parameter $f5$ needs to be set to $---$.

5.3.11 Lower Limit of Frequency P

Parameter P sends an alarm signal to port D upon Parameter E dropping below specified value of P . Accelerometer must be attached. Parameter $f3$ needs to be set to $-7-$ and Parameter $f6$ needs to be set to $---$.

5.3.12 Max Amplitude Index P

Set index P to restrict max amplitude of the vibratory feeder.

5.3.13 Max Adjustable Feed Speed Parameter H

Feed Speed Range is 0 to H . Parameter H restricts Maximum Feed Speed to a certain value to protect the vibratory feeder from high voltage caused by misoperation. Remote Speed Control feed speed is also affected by this parameter.

5.3.14 Phase Difference Parameter μ

Adjust Parameter μ to change phase of the output wave, default phase difference is 0° .

5.3.15 Max Output Voltage in Auto Frequency Measuring Process Parameter b

Output Voltage won't exceed the Parameter b value in Auto Frequency Measuring Process to protect the vibratory feeder from damage.

5.3.16 Frequency Searching Speed SP

This Parameter changes how fast the control searches frequency. This value can be set 1~5. The default is 5.

5.3.17 Feed Speed Minimum Adjustment Volume 

This Parameter is used to change the increment in which the feed speed adjusts. The default is 1. This Parameter can be set from 1~10.

5.3.18 Vibration Sensor Number 

SDVC34 Controls come with vibratory sensor number 205. 205 is the default setting.

Parameter Value	Model	Specification
		Acceleration of x axis/y axis/z axis
1	SDVS20-1	16g/16g/16g
2	SDVS20-2	35g/35g/---
3	SDVS20-3	50g/50g/---
4	SDVS20-4	70g/70g/---
203	SDVS203	8g/8g/8g
204	SDVS204	16g/16g/16g
205	SDVS205	32g/32g/32g
206	SDVS206	64g/64g/64g

Chapter VI Operating Modes

Operating Mode	Output Voltage U		Output Frequency f	
	Adjustment Method	$f5$ Setting	Adjustment Method	$f6$ Setting
Manual Mode	Manual	$_ _ _$	Manual	$_ _ _$
Auto Mode	Auto	$_ _ _$	Auto	$_ _ _$
Semi-Auto Mode	Auto	$_ _ _$	Manual	$_ _ _$
Sync Mode	Manual or Auto	$_ _ _$ or $_ _ _$	Auto Sync with Master Controller	$_ _ _$

6.1 Manual Mode

In Manual Mode, both Output Voltage and Output Frequency are manually adjusted.

Operating Mode	Output Voltage U		Output Frequency f	
	Adjustment Method	$f5$ Setting	Adjustment Method	$f6$ Setting
Manual Mode	Manual	$_ _ _$	Manual	$_ _ _$

To simplify the operation, Parameter $f5$ and $f6$ are set to $_ _ _$ by factory default. Under this setting the controller will work in Manual Mode if the Vibration Sensor is not connected to the controller or it will work in Auto Mode if the Vibration Sensor is connected.

Note:

If both $f5$ and $f6$ are set to $_ _ _$, the controller will work in Manual Mode whether or not the Vibration Sensor is connected to the controller. If the Vibration Sensor is not connected to the controller, the controller will always work in Manual Mode.

6.1.1 Output Voltage Parameter \cup Adjustment in Manual Mode

Actual Output Voltage value of the controller can be displayed on the LED screen digitally and accurately.

- Turn on the power switch when Vibration Sensor is not connected to the controller.
- The LED screen displays Output Voltage Parameter \cup and its value.
- Adjust the \cup value by pressing Vol+ or Vol- button.

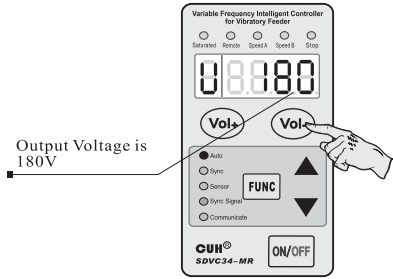

6.1.2 Output Frequency Parameter ϵ Adjustment in Manual Mode

Output frequency of the control is always stable and highly precise regardless of time or temperature change.

- Press "FUNC" button and hold for 2 seconds to enter Basic Parameter Adjustment Status.
- The LED screen displays Output Frequency Parameter ϵ and its value.
- Adjust the ϵ Value by pressing \blacktriangle or \blacktriangledown button when Vibration Sensor is not connected to the controller.

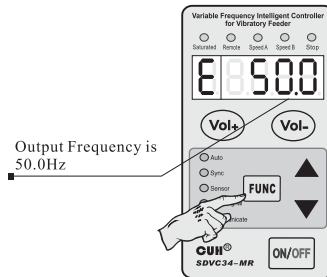

6.2 Auto Mode

In Auto Mode, Vibration Sensor must be connected to the controller. Output Voltage and Output Frequency will be adjusted automatically based on feedback from the Vibration Sensor to ensure constant preset feed speed and best vibration frequency. Output Voltage and Output Frequency can not be adjusted manually.

By factory default, when Vibration Sensor is connected, the controller works in Auto Mode.

Operating Mode	Output Voltage U		Output Frequency f	
	Adjustment Method	f5 Setting	Adjustment Method	f6 Setting
Auto Mode	Auto	---	Auto	---

Note:

The controller will still work in Manual Mode if Vibration Sensor is not connected.

6.2.1 Vibration Sensor Installation

Step One:

Connect the connector of the Vibration Sensor to the Vibration Sensor Socket of the controller.

Step Two:

Install the vibration sensor head on a secure and even surface of the vibratory feeder firmly.

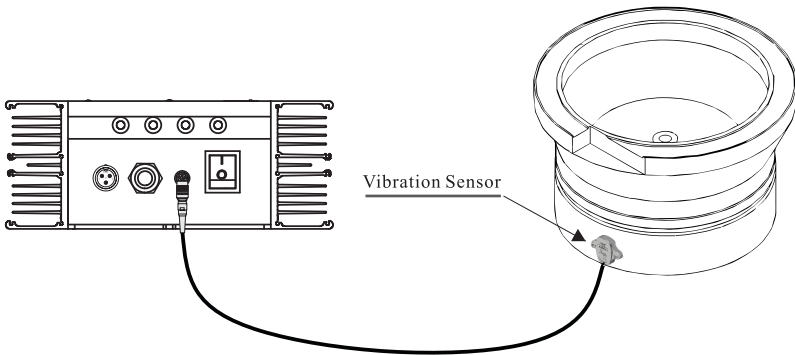

Note: Please plug and unplug the vibration sensor when the controller is powered off.

6.2.2 Feed Speed Parameter β Adjustment in Auto Mode

- Turn on the power switch when Vibration Sensor is connected to the controller. The Vibration Sensor Indicator lights up.
- The LED screen displays Feed Speed Parameter β and its value.
- Adjust the β Value by pressing "Vol+" or "Vol-" button to desired feed speed.

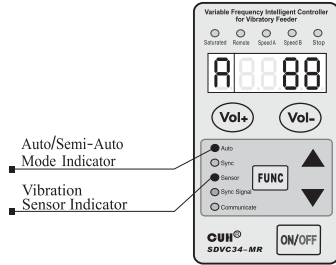

6.2.3 Auto Frequency Measuring in Auto Mode

By Auto Frequency Measuring, the controller detects the best vibration frequency of the vibratory feeder and sets all related parameters automatically. The only thing users need to do is to set Feed Speed Parameter β , then the controller will work in the best status.

- Press ▲ and ▼ buttons simultaneously and hold for 3 seconds when Vibration Sensor is connected to the controller to start Auto Frequency Measuring. Output Frequency Parameter ϵ and its value will be displayed on the LED screen in the measuring process.
- After the Auto Frequency Measuring process, the controller will automatically set all related parameters including Centre Frequency parameter F , Max Offset in Auto FM parameter α , Output Frequency Auto Adjustment Index $\uparrow F$, Amplitude Auto Adjustment Index $\uparrow P$, Amplitude Auto Adjustment Index $\downarrow P$, Phase Difference Parameter β . Output Voltage Adjustment Method Parameter $f5$ and Output Frequency Adjustment Method Parameter $f6$ will be set to _ _ _.

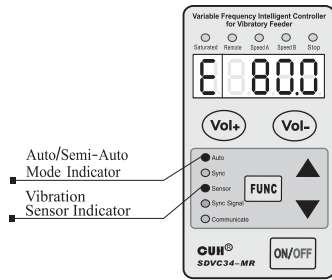

- If the LED Screen displays Err02 the moment Auto Frequency Measuring Process starts, it is normal, because of parameter b is set too high.
- If you want to cancel Auto Frequency Measuring Process, Press ON/OFF button. Then the controller will go back to the status before Auto Frequency Measuring.

After Feed Speed setting and Auto Frequency Measuring, the controller will work in best status at desired feed speed.

6.3 Semi-Auto Mode

In Semi-Auto Mode, the Vibration Sensor must be connected to the controller and Parameter f6 must be set to _ - _.

Output Voltage will be adjusted automatically based on feedback from the Vibration Sensor to ensure constant preset feed speed. Output Frequency will be adjusted manually.

Operating Mode	Output Voltage U		Output Frequency E	
	Adjustment Method	f5 Setting	Adjustment Method	f6 Setting
Semi-Auto Mode	Auto	---	Manual	- -

Note:

The controller will still work in Manual Mode if Vibration Sensor is not connected.

6.3.1 Vibration Sensor Installation

The same with Section 6.2.1

6.3.2 Semi Auto Mode Setup

Turn on the power switch when Vibration Sensor is connected to the controller. The Vibration Sensor Indicator will light up.

Press and hold "FUNC" and ▼ buttons simultaneously for 2 seconds to enter Auto/Sync Parameters.

Press "FUNC" button repeatedly until f6 is displayed.

Press ▲ or ▼ buttons to set f6 to _ - _

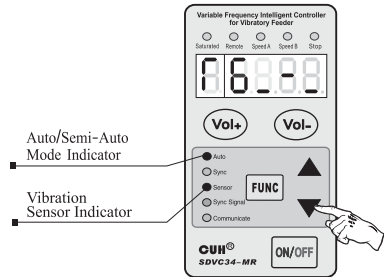

6.3.3 Feed Speed Parameter f Adjustment in Semi-Auto Mode

- Adjust the f Value by pressing "Vol+" or "Vol-" button to desired feed speed.

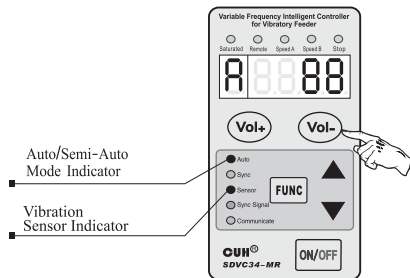

6.3.4 Output Frequency Parameter Ξ Adjustment in Semi-Auto Mode

- Press "FUNC" button and hold for 2 seconds to enter Basic Parameter Adjustment Status.
- The LED screen displays Output Frequency Parameter Ξ and its value.
- Adjust the Ξ Value by pressing ▲ or ▼ button.

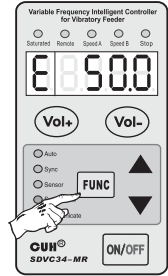

6.4 Sync Mode

In Sync Mode, sync signal wire must be connected between the Master and Slave Controllers. Output Frequency of the controller (Slave Controller) is always consistent with that of Master Controller. Output Voltage of the controller (Slave Controller) can be adjusted manually or automatically.

Operating Mode	Output Voltage U		Output Frequency f	
	Adjustment Method	$f5$ Setting	Adjustment Method	$f6$ Setting
Sync Mode	Manual or Auto	— — or ---	Auto Sync with Master Controller	==

Sync Mode applies to the situation that there are more than one controller controlling several vibratory feeders in the feed system, output of the controllers are not synchronous so they interfere with each other, known as Cross Talk (Beat Effect). Sync Mode is designed to eliminate Cross Talk as output waveform of Master and Slave Controllers are exactly synchronous.

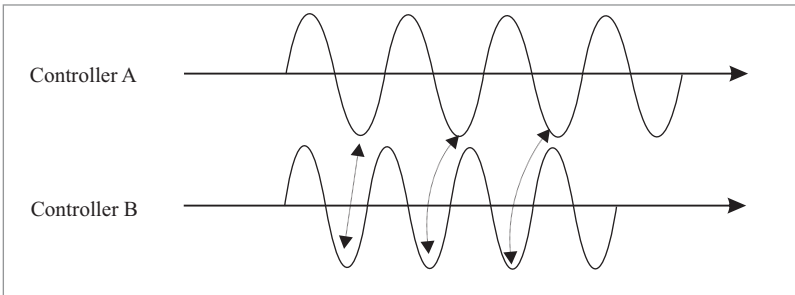

Controller B is not set to Sync Mode, Output Waveforms of the two controllers are not synchronous.

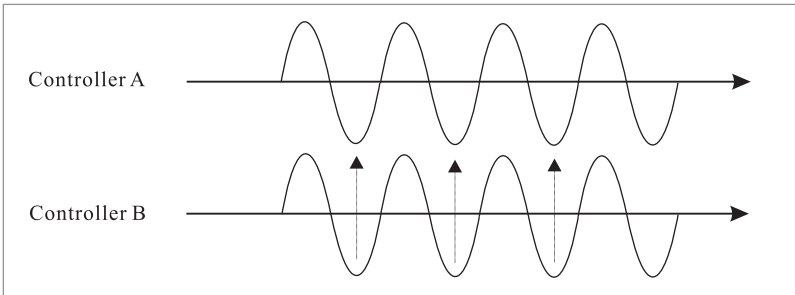

Controller B is set to Sync Mode, Output Waveforms of the two controllers are synchronous.

6.4.1 Connection Method of the Sync Signal Wire between Master and Slave Controllers

Step 1:

Open the cover plates of the signal control ports boxes of both controllers.

Step 2:

Connect the Sync Signal Wire between Master and Slave controllers according to the schematic diagram below.

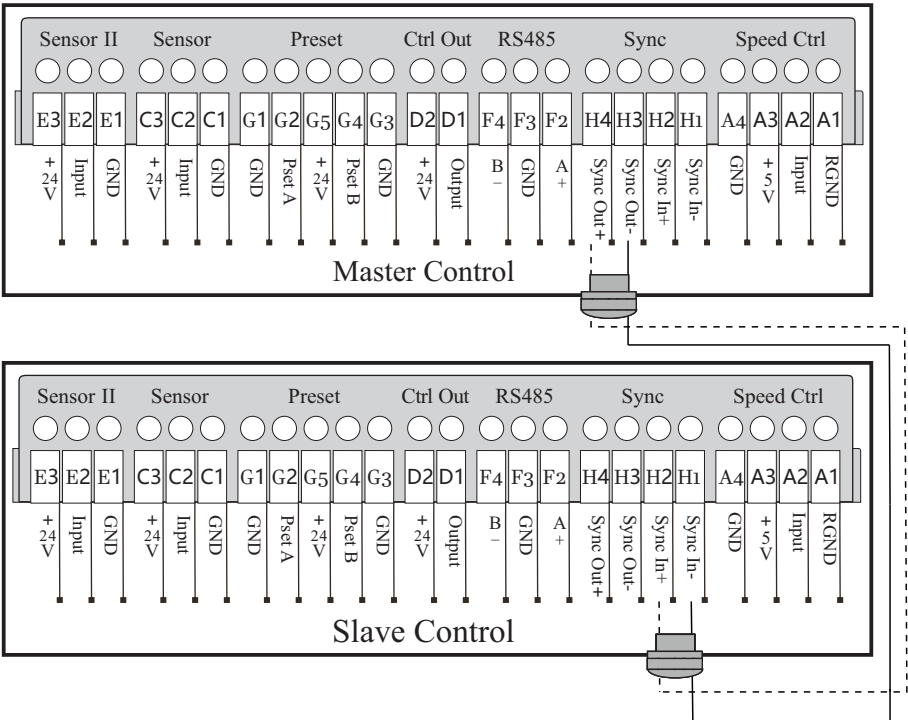

One Master Controller could drive several Slave Controllers.

6.4.2 Sync Mode Applications

Sub-Pattern 1

Controller	Output Voltage \bar{U}		Output Frequency \bar{E}	
	Adjustment Method	f_5 Setting	Adjustment Method	f_6 Setting
Master Controller	Manual	--	Manual	--
Slave Controller	Manual	--	Auto Sync with Master Controller	==

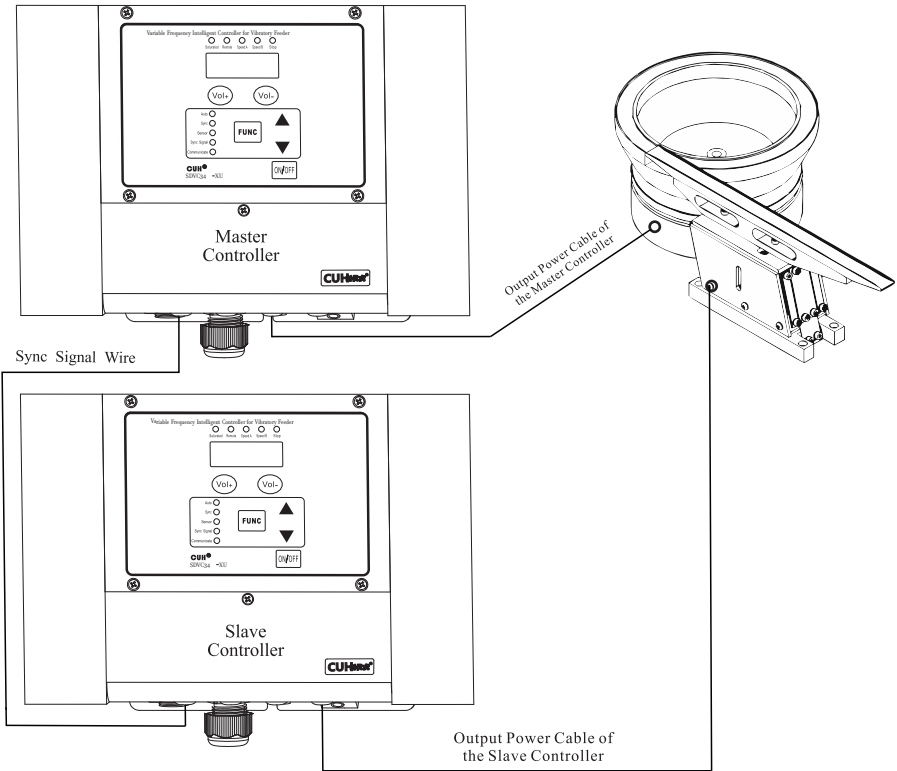

Sub-Pattern 2

Controller	Output Voltage \bar{U}		Output Frequency \bar{f}	
	Adjustment Method	f_5 Setting	Adjustment Method	f_6 Setting
Master Controller	Auto	---	Auto	---
Slave Controller	Manual	- --	Auto Sync with Master Controller	- -- ---

Sub-Pattern 3

Controller	Output Voltage \bar{U}		Output Frequency \bar{f}	
	Adjustment Method	f_5 Setting	Adjustment Method	f_6 Setting
Master Controller	Auto	---	Manual	- --
Slave Controller	Manual	- --	Auto Sync with Master Controller	- -- ---

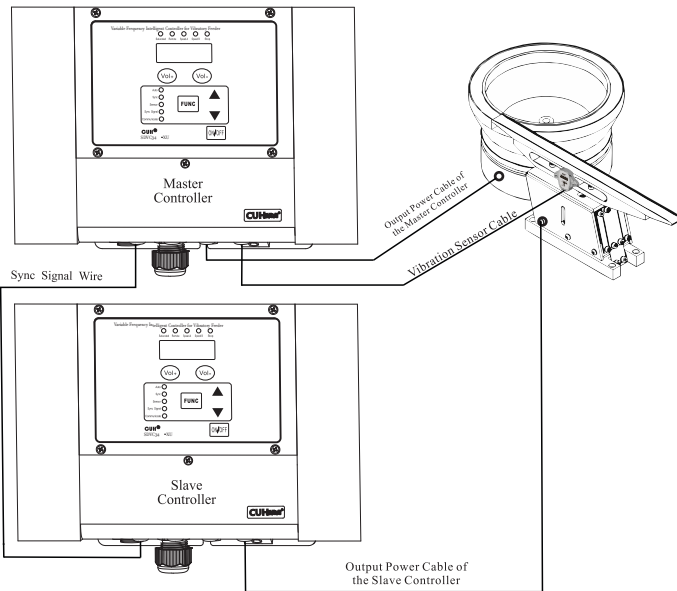

Sub-Pattern 4

Controller	Output Voltage U		Output Frequency ϵ	
	Adjustment Method	$f5$ Setting	Adjustment Method	$f6$ Setting
Master Controller	Manual	--	Manual	--
Slave Controller	Auto	---	Auto Sync with Master Controller	--

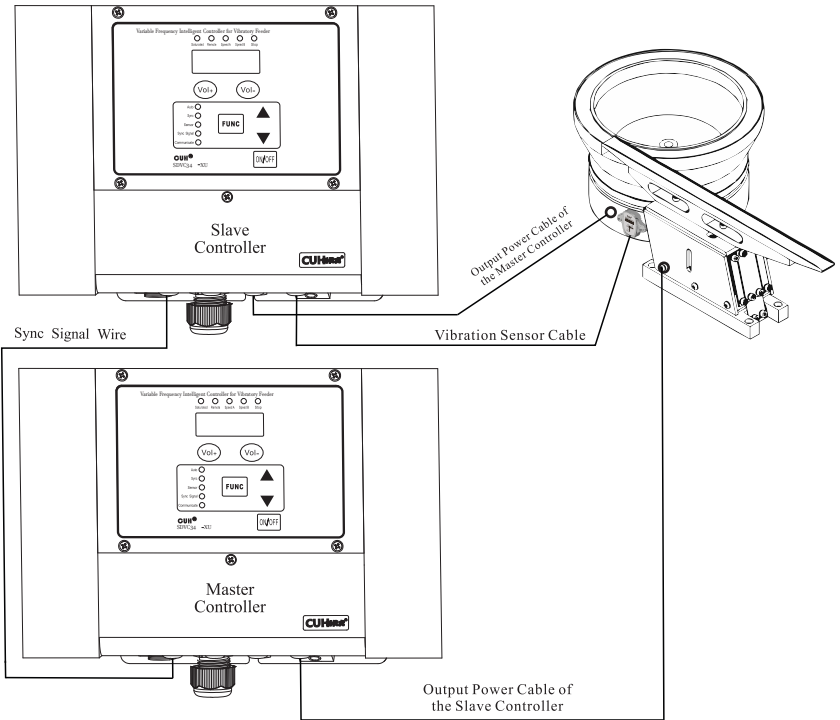

Sub-Pattern 5

Controller	Output Voltage U		Output Frequency f	
	Adjustment Method	f_5 Setting	Adjustment Method	f_6 Setting
Master Controller	Auto	---	Auto	---
Slave Controller	Auto	---	Auto Sync with Master Controller	---

Sub-Pattern 6

Controller	Output Voltage U		Output Frequency f	
	Adjustment Method	f_5 Setting	Adjustment Method	f_6 Setting
Master Controller	Auto	---	Manual	--
Slave Controller	Auto	---	Auto Sync with Master Controller	--

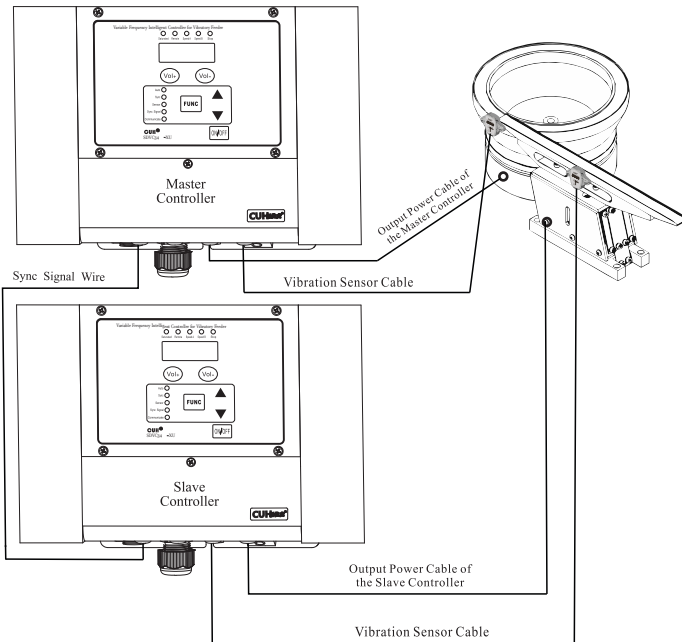

Chapter VII Signal Control

Signal Control includes: C Ports ON/OFF Control, E Ports ON/OFF Control, Remote Speed Control, Storage and Output of Preset Speeds, Rs485 Communication and 24V DC Control Output.

7.1 C Ports and E Ports ON/OFF Control

Output of the controller can be turned on or off by any kind of switch, sensor or PLC via C Ports and E ports.

7.1.1 Connection Method of Different Kinds of Switch Sensors and PLC to C Ports and E Ports

7.1.1.1 Connection Method of the Proximity Sensor to C Ports and E Ports

Both the C Port (Sensor) and E Port (Sensor II) are wired the same using E3, E2, E1 and C3, C2, C1. Sensor and Sensor II can be used independently or together.

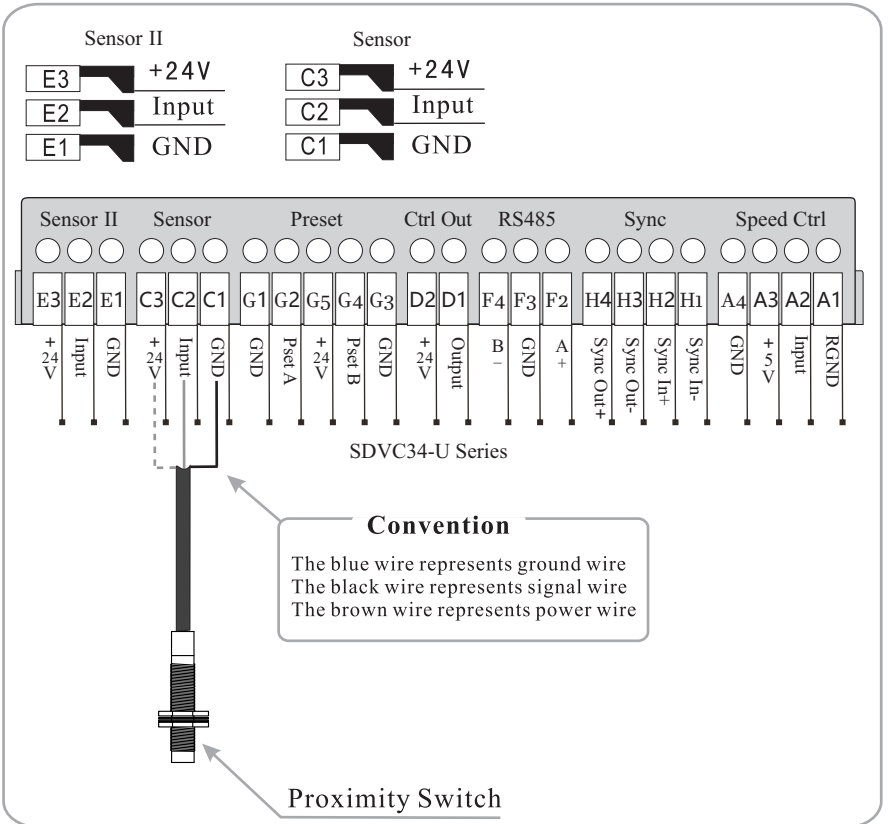

7.1.1.2 Connection Method of the Photoelectric Couple Sensor to C Ports

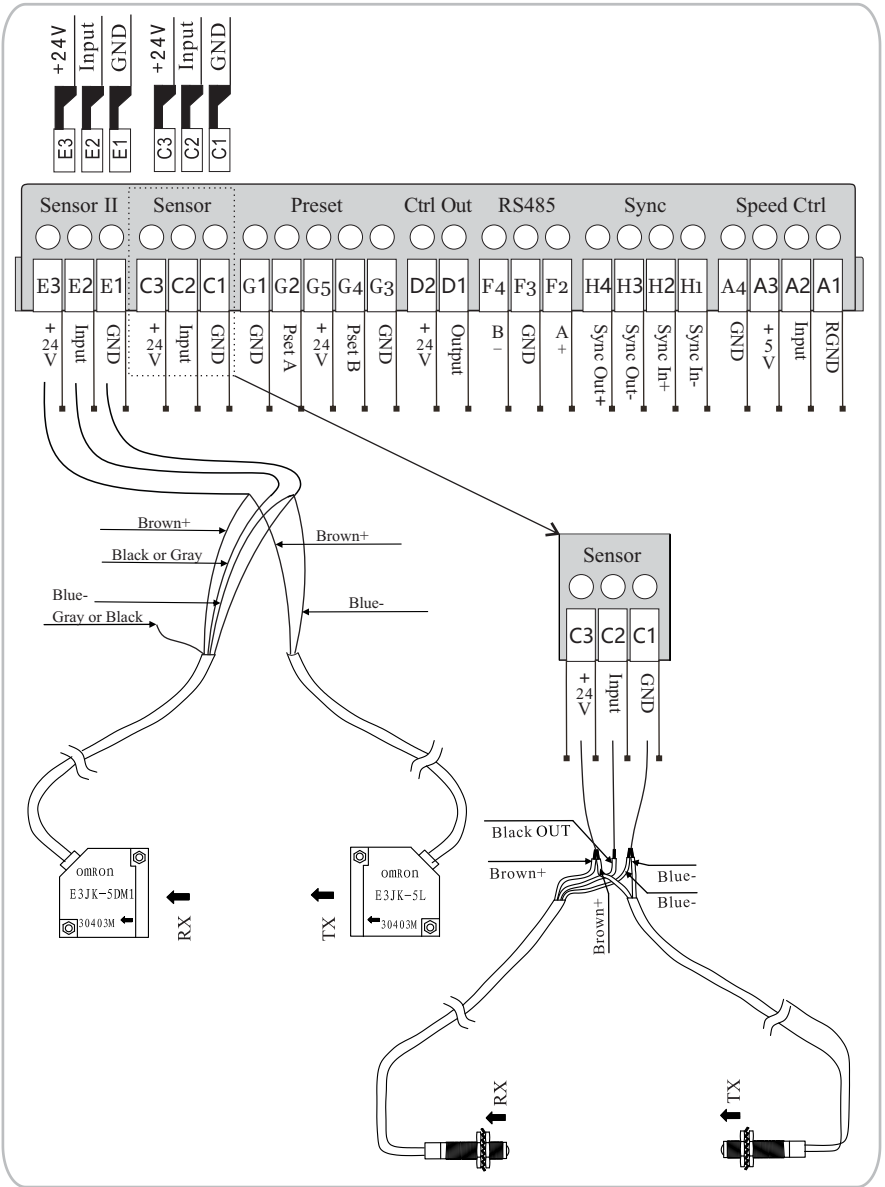

7.1.1.3 Connection Method of the Photoelectric Reflective Sensor to C Ports

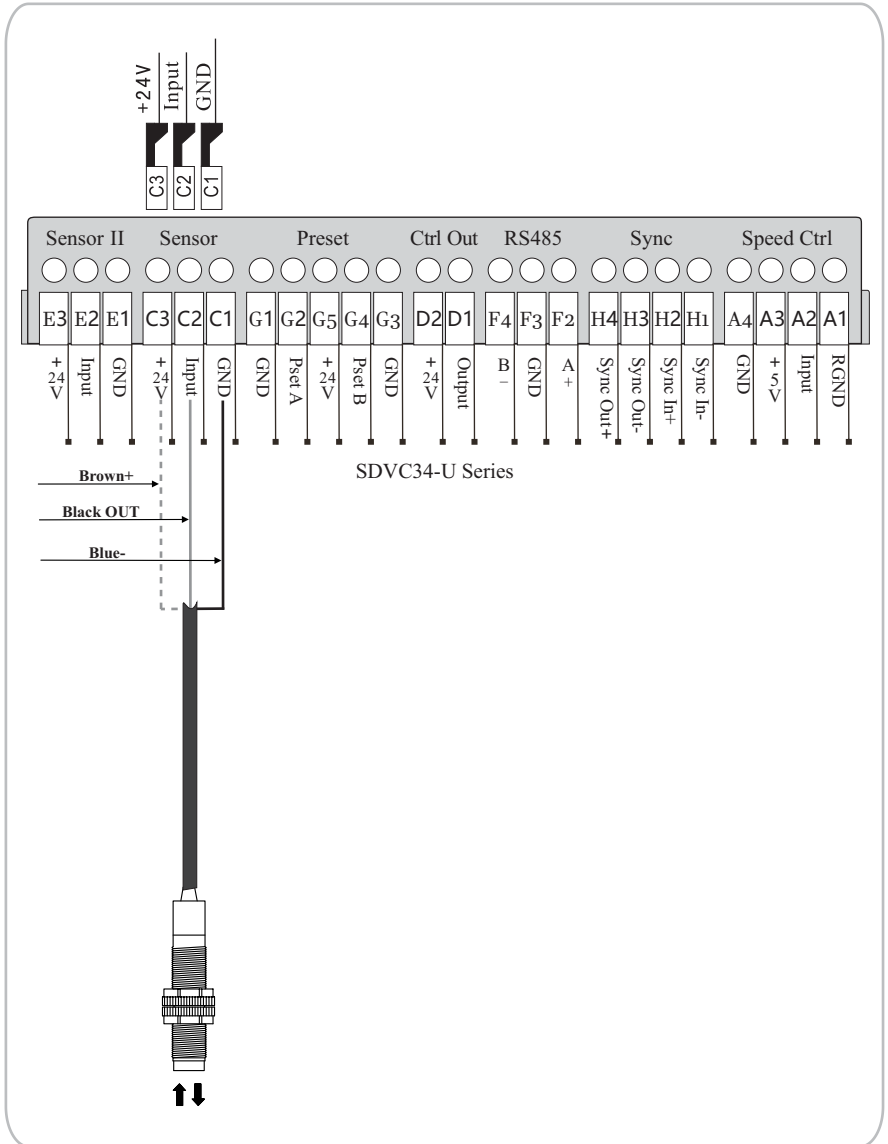

7.1.1.4 Connection Method of the Fiber Optic Couple Sensor to C Ports

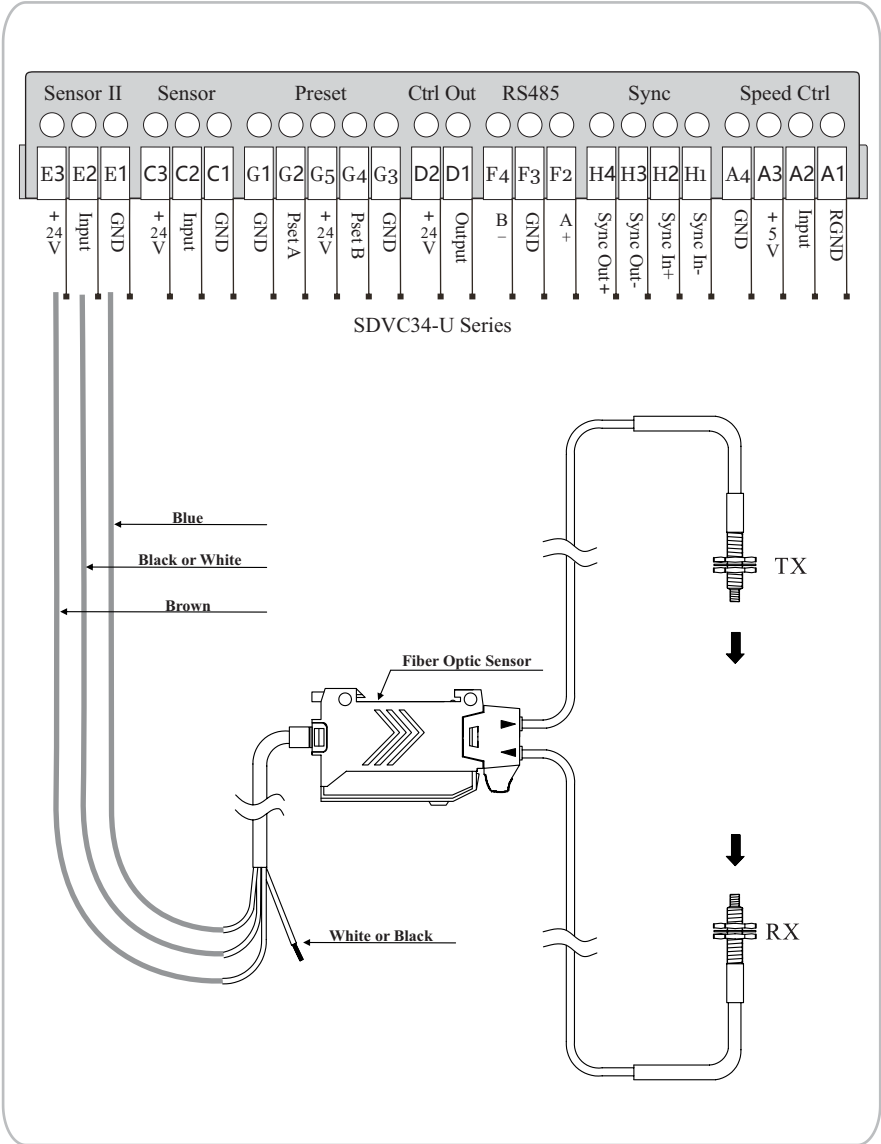

7.1.1.5 Connection Method of the PLC to C Ports

Relay output, NPN output and PNP output of the PLC, any one of them can turn on/off the controller.

Connection Method of the NPN output of the PLC to C Ports

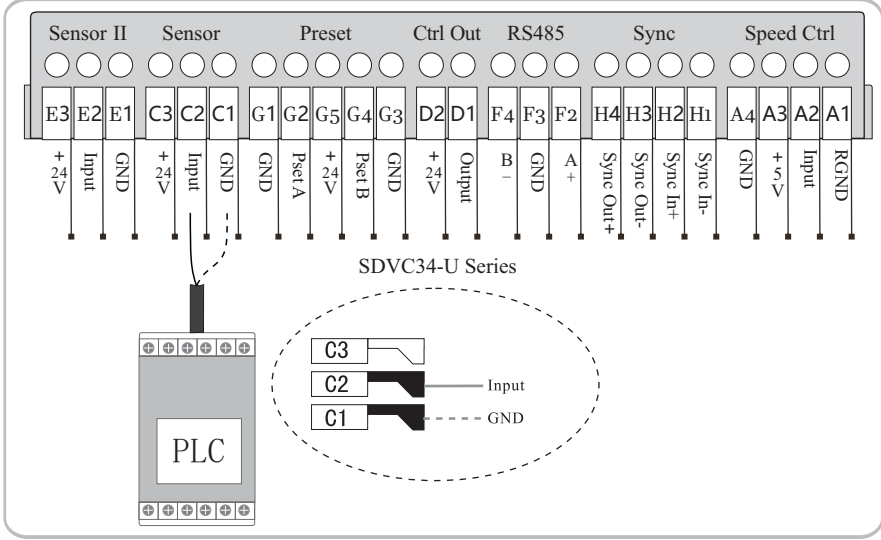

Connection Method of the PNP output of the PLC to C Ports

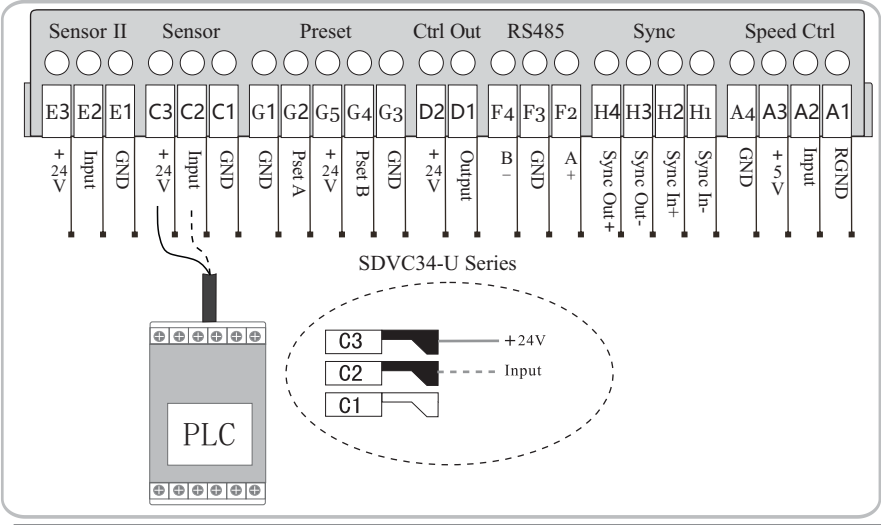

7.1.2 C Ports and E Ports ON/OFF Delay

7.1.2.1 C Port ON/OFF Delay

If you want the controller to start outputting after a period of time from receiving the C Ports ON Control Signal, adjust Parameter J.

If you want the controller to go on outputting for a period of time after receiving the C Ports OFF Control Signal, adjust Parameter L.

C Ports ON Delay Parameter J

The period of time from when the controller receives the C Ports ON Control to the start of the output.

- Press “FUNC” button and hold for 2 seconds to enter Basic Parameter Adjustment Status.
- Press “FUNC” button repeatedly to cycle through Parameters until you get to J.
- Press ▲ or ▼ button to adjust the J value. The parameter unit is in seconds, and the adjustment accuracy is 0.1.

ON Delay Time is set as 2 seconds

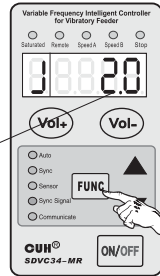

C Ports OFF Delay Parameter L

The period of time from when the controller receives the C Ports OFF Control Signal to when it cuts off the output.

- Press “FUNC” button and hold for 2 seconds to enter Basic Parameter Adjustment Status.
- Press “FUNC” button repeatedly to cycle through Parameters until you get to L.
- Press ▲ or ▼ button to adjust the L value. The parameter unit is in seconds, and the adjustment accuracy is 0.1.

OFF Delay Time is set as 1.5 seconds

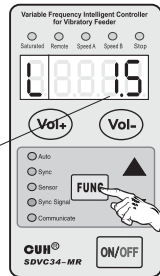

7.1.2.2 E Port ON/OFF Delay

If you want the controller to start outputting after a period of time from receiving the E Ports ON Control Signal, adjust Parameter J-.

If you want the controller to go on outputting for a period of time after receiving the E Ports OFF Control Signal, adjust Parameter L-.

E Ports ON Delay Parameter J-

The period of time from when the controller receives the E Ports ON Control to the start of the output.

- Press and hold “FUNC” and ▲ buttons for 2 seconds to enter Advanced Parameter Adjustment Status.
- Press “FUNC” button repeatedly to cycle through Parameters until you get to J-.
- Press ▲ or ▼ button to adjust the J- value. The parameter unit is in seconds, and the adjustment accuracy is 0.1.

ON Delay Time is set as 2 seconds

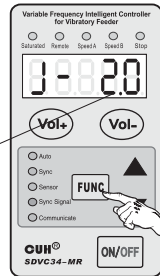

E Ports OFF Delay Parameter L-

The period of time from when the controller receives the E Ports OFF Control Signal to when it cuts off the output.

- Press and hold “FUNC” and ▲ for 2 seconds to enter Advanced Parameter Adjustment Status.
- Press “FUNC” button repeatedly to cycle through Parameters until you get to L-.
- Press ▲ or ▼ button to adjust the L- value. The parameter unit is in seconds, and the adjustment accuracy is 0.1.

OFF Delay Time is set as 1.5 seconds

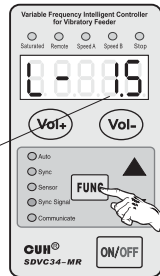

7.2 C Ports and E Ports Logical Relation

7.2.1 C Ports ON/OFF Control Logical Relation Parameter r_2

By factory default, the controller runs when C Ports receives no signal. But in some other applications the controller needs to be stopped when C Ports receives no signal. Adjust Parameter r_2 to meet either of the requirements.

- Press and hold “FUNC” and ▲ buttons for 2 seconds to enter Advanced Parameter Adjustment Status.
- Press “FUNC” button repeatedly to cycle through Parameters until you get to r_2 .
- Press ▲ or ▼ button to change the logical relation.

Parameter r_2 is set to ___ by default

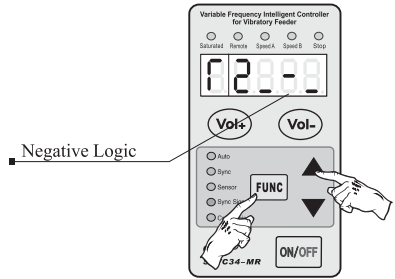
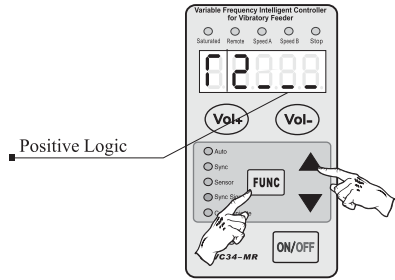

- When Parameter r_2 is set to ____, output of the controller will be on when C Ports receives no signal.
- When Parameter r_2 is set to _-, output of the controller will be off when C Ports receives no signal.

7.2.2 E Ports ON/OFF Control Logical Relation Parameter f_7

By factory default, the controller runs when E Ports receives no signal. But in some other applications the controller needs to be stopped when E Ports receives no signal. Adjust Parameter f_7 to meet either of the requirements.

- Press "FUNC" and ▲ buttons simultaneously and hold for 2 seconds to enter Advanced Parameter Adjustment Status
- Press "FUNC" button 3 times to switch to Parameter f_7 .
- Press ▲ or ▼ button to change the logical relation.

Parameter f_7 is set to ___ by default

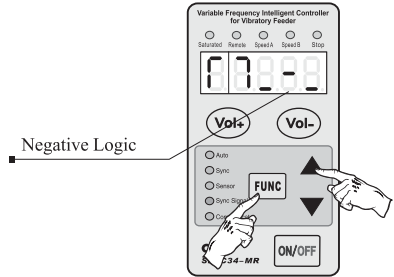
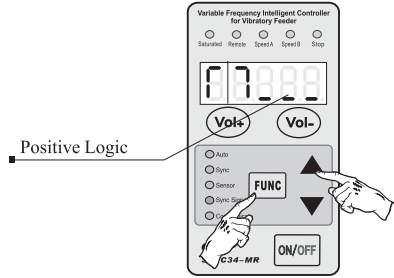

- When Parameter f_7 is set to ___ , output of the controller will be on when E Ports receives no signal.
- When Parameter f_7 is set to _ _ , output of the controller will be off when E Ports receives no signal.

7.3 Common Parameters of C Ports and E Ports

7.3.1 Logical Relation Parameter \sqcap of C Ports and E Ports

Parameter \sqcap determines the reaction of the controller when both C Ports and E Ports are effective.

- Press "FUNC" and ▲ buttons simultaneously and hold for 2 seconds to enter Advanced Parameter Adjustment Status.
- Press "FUNC" button 8 times to switch to Parameter \sqcap .
- Press ▲ or ▼ button to change the logical relation.

Logical Relation: AND \sqcap
 Output of the controller will be ON only when both the Ports require the controller to run

Logical Relation: OR \sqcup
 Output of the controller will be ON when either or both of the Ports require the controller to run

Logical Relation: XOR \sqcirc
 Output of the controller will be ON only when one of the Ports requires the controller to run and the other requires the controller to stop.

Default Logical Relation is **AND**

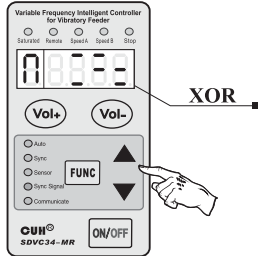
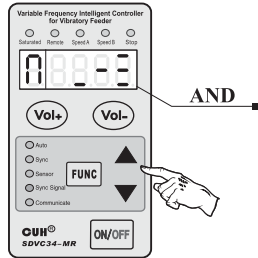
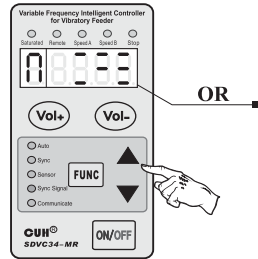
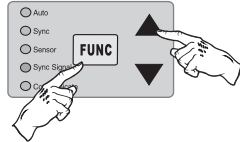

7.3.2 Switch Sensor Type Parameter f 8

The controller can automatically recognize type of the Switch Sensor, NPN or PNP. Users can also set the Switch Sensor Type manually.

Press and hold “FUNC” and ▲ buttons for 2 seconds to enter Advanced Parameter Adjustment Status.

Press “FUNC” button repeatedly to cycle through Parameters until you find f 8 .

Press ▲ or ▼ button to change the value.

- Uto:** Switch Sensor Type automatic recognition
- nPn:** NPN Type Switch Sensor
- PnP:** PNP Type Switch Sensor

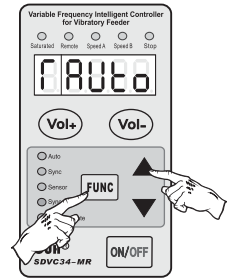

7.3.3 Whether or not output of the controller is controlled by ON/OFF Control Signal Parameter f 4

Ctrl Out 24V DC Port D will be on when the control is on, and off when the control is off if f 4 is set to _ _ _ (Will correlate to stop indicator). Ctrl Out 24V DC Port D will be on regardless of the control being on or off if f 4 is set to - - - (Will not correlate to stop indicator)

Press and hold “FUNC” and ▲ buttons for 2 seconds to enter Advanced Parameter Adjustment Status.

Press “FUNC” button repeatedly to cycle through Parameters until you find f 4 .

Press ▲ or ▼ button to change the value of f 4 .

_ _ _ means correlated

- - - means not correlated

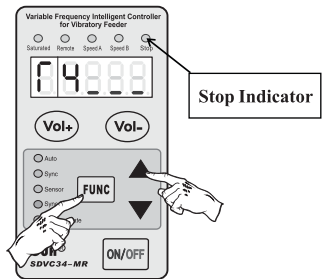

Parameter f 4 is set to _ _ _ by factory default

7.3.4 D Port Ctrl Out Logic Relation

This parameter is used when f_3 is controlled by an alarm signal. This parameter controls positive and negative logic for the alarm signal.

Press and hold “FUNC” and ▲ buttons for 2 seconds to enter Advanced Parameter Adjustment Status.

Press “FUNC” button repeatedly to cycle through Parameters until you find f_8 .

Press ▲ or ▼ button to change the value of f_8 .

- - - Main logic (set by default)
- - Second set of logic
- - Parameter setting of the second set of logic

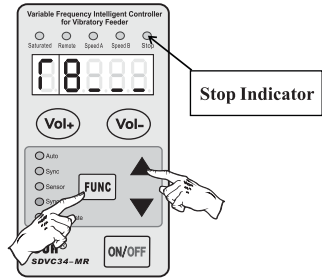

7.4 Remote Speed Control

Output Voltage/Feed Speed can be controlled by a potentiometer or a 1-5V/4-20mA DC Control Signal remotely.

When Remote Speed Control voltage exceeds 0.5V, it will begin controlling the Output Voltage/Feed Speed while Vol+ and Vol- buttons will no longer have an effect. In the process of Remote Speed Control, the Remote Speed Control Indicator will light up and the LED Screen will display Output Voltage/Feed Speed and its value.

Connection Method of the Remote Speed Control Potentiometer

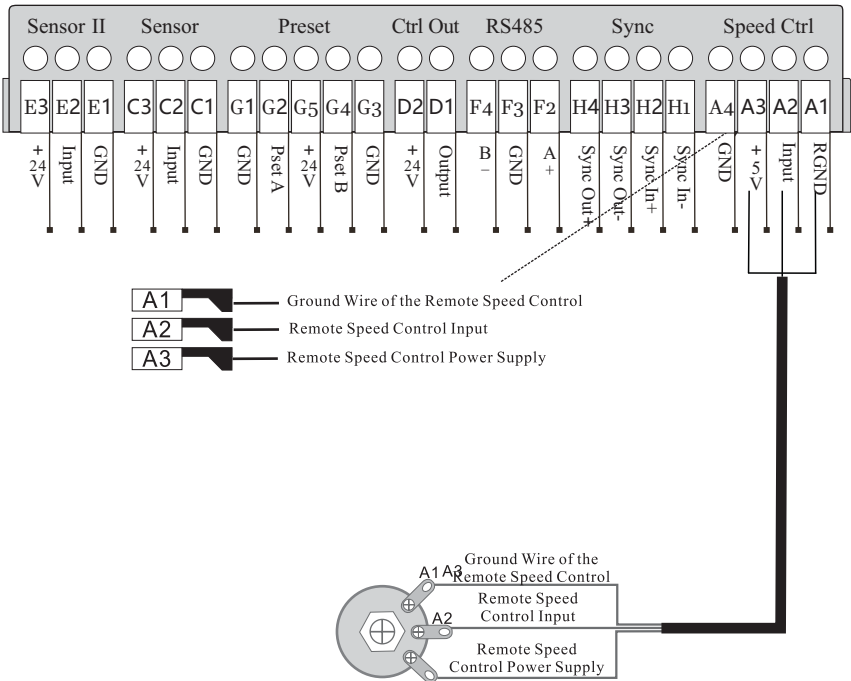

Connection Method of the Remote Speed Control PLC

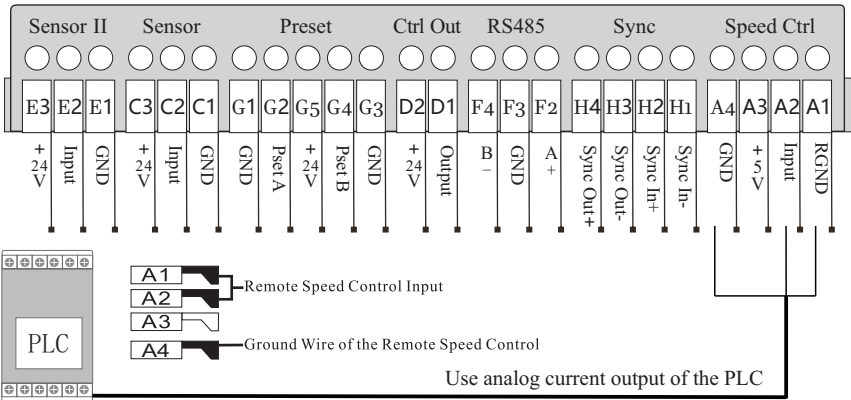
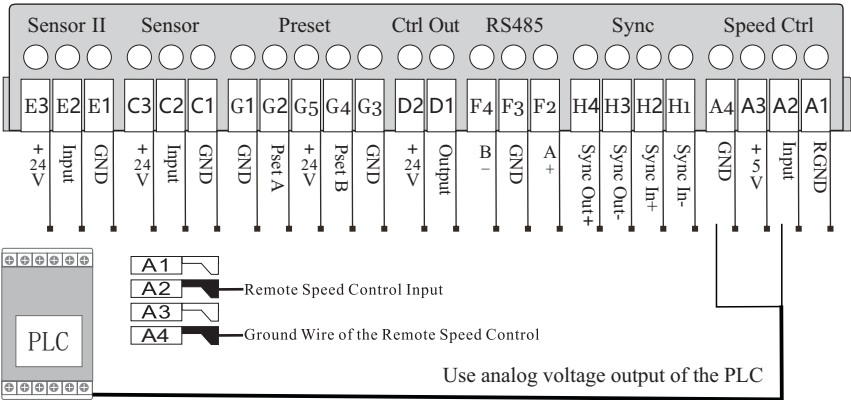

Remote Speed Control Signal	Output Voltage/Feed Speed
less than 0.5V	Controlled by Vol+ and Vol- buttons
0.5V-1V	Output Voltage: 0V/Feed Speed: 0 Controlled by Remote Speed Control Signal
1~5V/4~20mA	Output Voltage/Feed Speed is Linearly Controlled by Remote Speed Control Signal

7.5 Storage and Output of Preset Speeds

The controller can store and output 4 different Preset Speeds. The 4 kinds of ON/OFF combination of Speed A Indicator and Speed B Indicator correspond respectively to Speed 1, Speed 2, Speed 3 and Speed 4.

Preset Speed	G1 & G2 Ports		G3 & G4 Ports	
	Speed A Indicator	Switch 1	Speed B Indicator	Switch 2
Speed 1	ON	Closed	OFF	Open
Speed 2	OFF	Open	ON	Closed
Speed 3	ON	Closed	ON	Closed
Speed 4	OFF	Open	OFF	Open

Connection Method of Preset Speeds

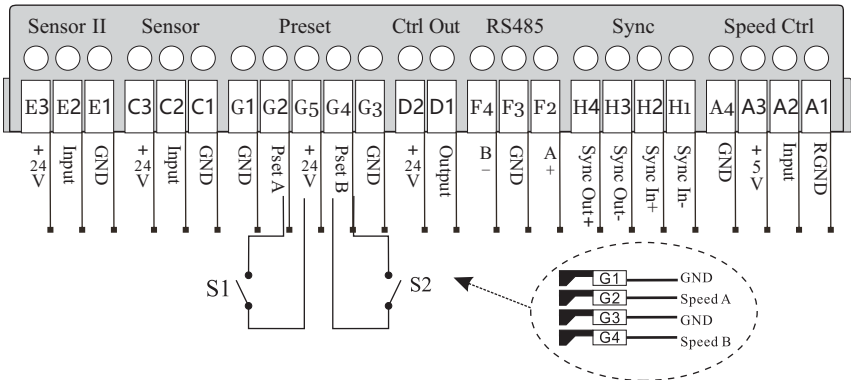

Storage of Preset Speeds

- Take the storage of Speed 1 for example:
- Close S1, Speed A Indicator lights up, open S2, Speed B Indicator goes off
To get desired feed speed:
In Manual Mode, adjust Output Voltage parameter U and Output Frequency parameter E
In Auto Mode, adjust Feed Speed parameter A
In Semi-Auto Mode, adjust Feed Speed parameter A and Output Frequency parameter E
- Speed 1 stored automatically

Output of Preset Speeds

- Take the output of Speed 1 for example:
- Close S1 again, Speed A Indicator lights up, open S2 again, Speed B Indicator goes off
The controller will output Speed 1 instantly

7.6 RS485 Communication

All parameters of the controller can be adjusted remotely via RS485 Communication Ports.

7.6.1 RS485 Communication Address Parameter ¶

Parameter ¶ represents ID number of the controller in RS485 communication.

Range of the parameter: 1 to 31

Make sure Communication Address of all controllers in the same network are different to distinguish controllers from each other.

- Press "FUNC" and ▲ buttons simultaneously and hold for 2 seconds to enter Advanced Parameter Adjustment Status
- Press "FUNC" button repeatedly until you get to the ¶ parameter.
- Press ▲ or ▼ button to change the ¶ value.

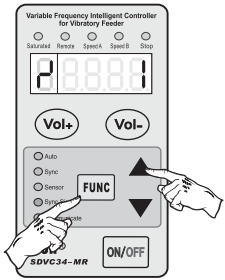

7.6.2 RS485 Communication Baud Rate Parameter ¶

RS485 Communication Baud Rate can be: 3, 12, 24, 96, 192, 576 or 1152.

Unit: 0.1 Kbps

Default Value: 9.6 Kbps

Controllers in the same network should use the same Baud Rate.

- Press "FUNC" and ▲ buttons simultaneously and hold for 2 seconds to enter Advanced Parameter Adjustment Status
- Press "FUNC" button repeatedly until you get to the ¶ parameter.
- Press ▲ or ▼ button to change the ¶ value.

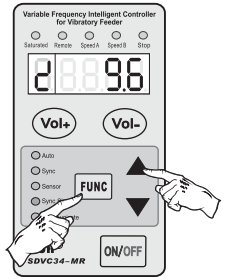

7.6.3 RS485 Communication Protocol

RS485 Communication Protocol is available in the Download column of our website:

www.bryantcontrol.com

Note: Due to the limited number of times the controller Non volatile memory can be erased, the 485 save instruction needs to be manually executed after modifying the parameters to avoid frequently sending save instructions through the program.

7.7 24V DC Control Output

The controller can output 24V DC Control power to drive a solenoid valve, an electrical relay or a PLC etc coordinating with C Ports/E Ports ON/OFF Control.

7.7.1 Connection Method of the 24V DC Control Output

Connection to a solenoid valve:

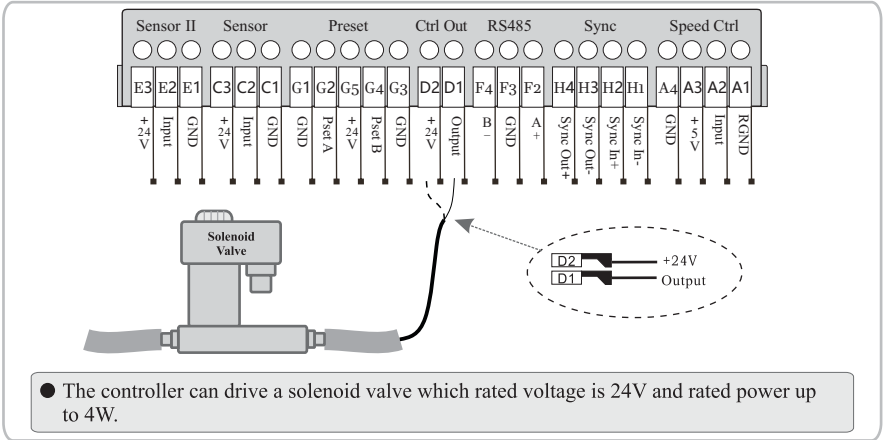

Connection to an electrical relay:

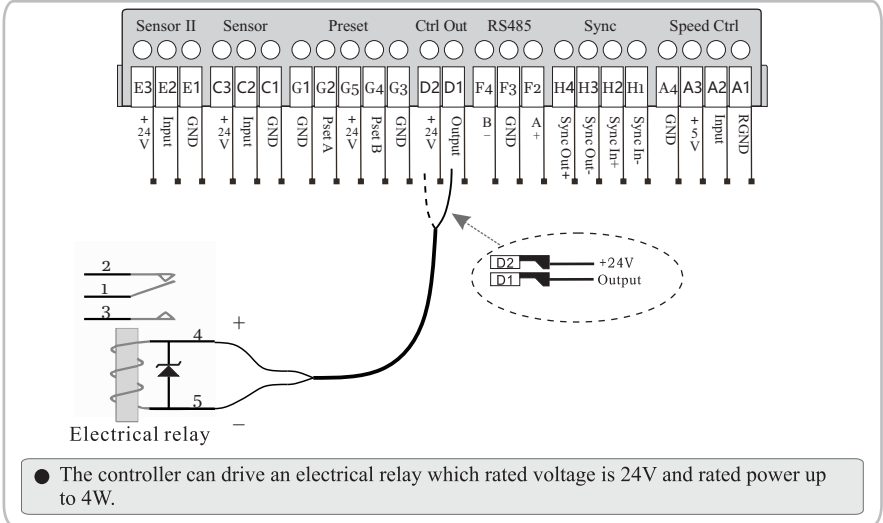

Note: Please connect the positive and negative poles of the relay or solenoid valve correctly: D2 is connected to the positive pole, D1 is connected to the negative pole. Reversing the connection may cause short circuit damage to the control output.

7.7.2 Logical Relation of the 24V DC Control Output

- Press "FUNC" and ▲ buttons simultaneously and hold for 2 seconds to enter Advanced Parameter Adjustment Status.
- Press "FUNC" button repeatedly until you get to the f 3 parameter.
- Press ▲ or ▼ button to change the logical relation.

- If Parameter f 3 is set to _ _ _ , 24V DC Control Output will be on when Output of the controller is on.
- If Parameter f 3 is set to _ - _ , 24V DC Control Output will be off when Output of the controller is on.

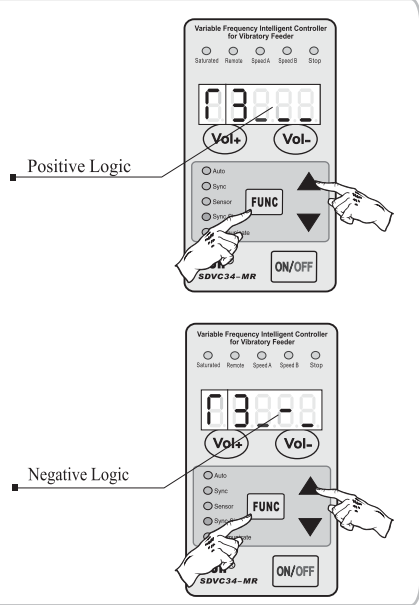

7.8 Controlling Alarm Signal

SDVC34 control output signal alarm mode means: When the amplitude sensor is connected, if certain parameter values fall below the set threshold(value), an alarm signal will be output at port D to alert the user.

The specific operational steps are as follows:

1. Set the value of parameter f 3 to - _ _ .
2. When it is necessary to monitor whether the output voltage of the controller is below a certain value, follow the steps below:
 - A. Connect the acceleration sensor to the controller.
 - B. Set the value of parameter f 5 to _ _ _ (indicating automatic voltage).
 - C. Set the parameter "output voltage lower limit value" f 6 to a value deemed reasonable by the user. If the output voltage value of f 6 the controller is less than the "output voltage lower limit value, f 6" the control output is in the alarm state (with output), otherwise it is in the normal state (without output).
3. When it is necessary to monitor whether the output frequency of the controller is below a certain value, follow the steps below:
 - A. Connect the acceleration sensor to the controller.
 - B. Set the value of parameter 6 to 1 (indicating automatic frequency).
 - C. Set the parameter "output frequency lower limit value" f 7 to a value deemed reasonable by the user. If the output frequency f 7 of the controller is less than the "output frequency lower limit value f 7," the control output is in the alarm state (with output), otherwise it is in the normal state. (without output).

7.9 Save and Restore Parameter Settings

7.9.1 Save User Parameter Settings or Factory Default Settings

Save user parameter settings to controller memory

Step 1, Set **Pin** parameter to **Pin5**

Step 2, Switch to the flashing **SABE** parameter. Press and hold the ▼ button, then you will see **SABUr** displayed on the screen, meaning user parameter settings are successfully saved.

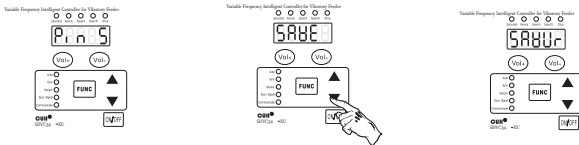

7.9.2 Save factory default settings to controller memory

Step 1, Set **Pin** parameter to **Pin55**

Step 2, Switch to the flashing **SABE** parameter. Press and hold the ▼ button, you will see **SABFA** and then **----** displayed on the screen, meaning factory default settings are successfully saved and meanwhile the controller is reset to factory default.

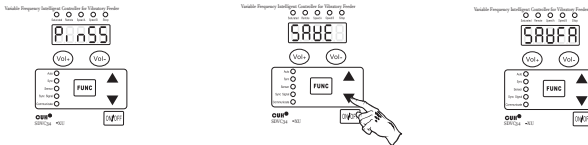

Note: Be aware that if **Pin** parameter is set to neither **Pin5** nor **Pin55**, **PinEr** will be displayed on the screen when you try to save parameter settings, meaning parameter saving pin is incorrect and parameter settings can not be saved.

5.4.3 Restore The Controller To Memory Saved Settings

Switch to the flashing **88888** parameter. Press and hold the ▲ button, you will see **----** displayed on the screen, meaning controller memory saved settings are successfully restored to the controller.



Chapter VIII Security Functions

8.1 Automatic Voltage Regulation

Eliminate feed speed variation caused by input voltage fluctuation and cross-talk (beat effect) caused by industrial AC frequency.

8.2 Short-Circuit Protection

If output of the controller is short-circuited, the controller will stop its output and display Err01 on the LED screen until restarted.

8.3 Overcurrent Protection

If output current exceeds its rated value by misoperation, the controller will stop its output to ensure operating safety and display Err02 on the LED screen.

8.4 Overheat Protection

If internal temperature of the controller exceeds 65°C, the controller will stop its output to protect itself and display Err02 on the LED screen until internal temperature fall below 60°C.

8.5 Overload Protection

When Vibration Sensor is connected to the controller, if vibration amplitude exceeds Max Amplitude Index setting, the controller will turn down its output to protect the vibratory feeder.

8.6 Overvoltage Protection

If input voltage is much higher than rated input voltage range, fuse inside the controller will be blown to protect the controller from further damage. Please contact us for repair.

Appendix A: Dimensions



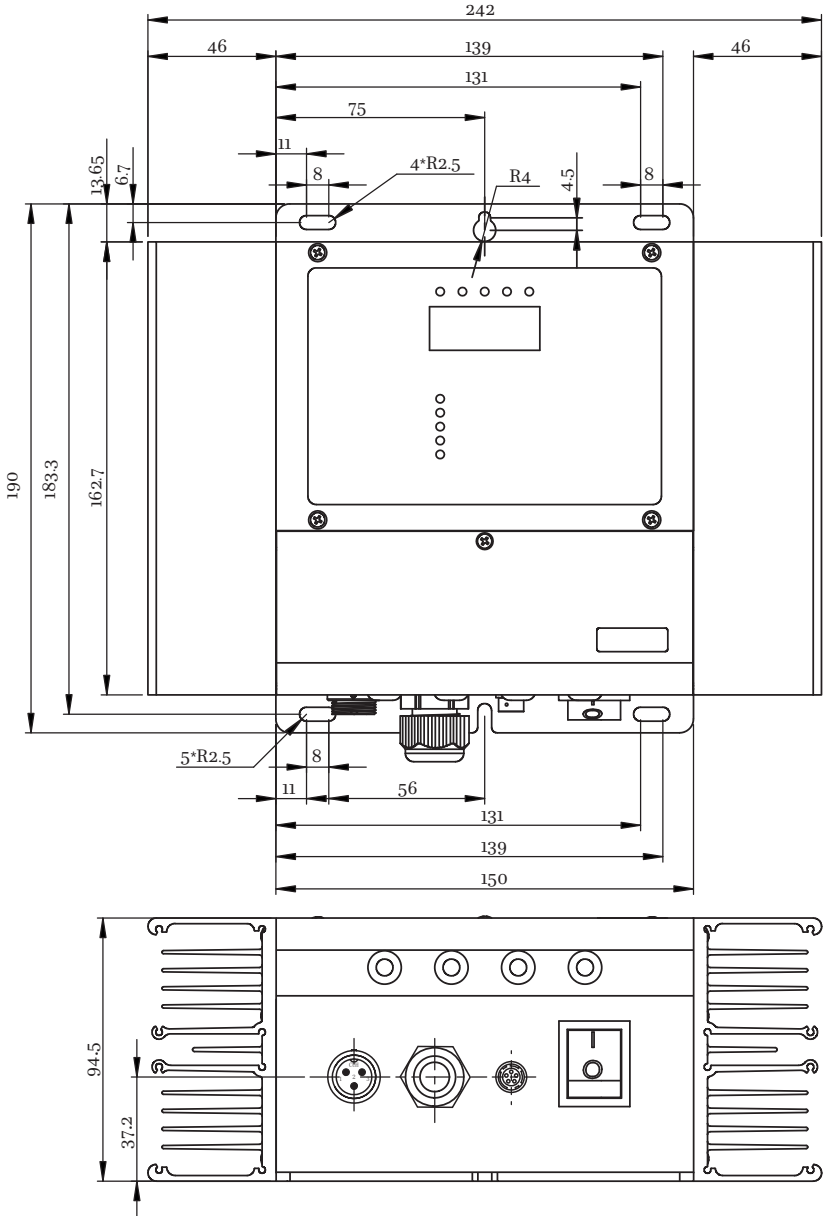

SDVC34-UR Unit: mm







Appendix B: Electrical Specification

Item	Min	Typical	Max	Unit	Note
Input Voltage	85	110	250	V	AC RMS
Adjustable Output Voltage Range	0	—	250	V	Lower than 150% of Input Voltage
Voltage Adjustment Accuracy	1			V	
Voltage Regulation Accuracy	0	—	10	%	$\Delta V_{out}/\Delta V_{in}$
Response Time of Voltage Regulation	0.0025	—	0.04	s	the period of output voltage
Adjustable Output Current Range	0	—	10	A	SDVC34-UR
			15		SDVC34-XU
Output Frequency	5	—	400	Hz	
Frequency Adjustment Accuracy		0.1		Hz	
Output Waveform	Sine				
Soft Start Time	0	—	10	s	Default value: 0.5
On/Off Delay Time Range	0	—	20	s	Default value: 0.2
On/Off Delay Time Accuracy		0.1		s	
Overheat Protection Trigger Temperature	60	65	65	°C	
Digital Communication	ModBUS485 Communication				RTU and ASCII
DC Control Output Current	0	—	200	mA	
DC Control Output Voltage	22	24	26	V	
Analog Control Signal	1~5/4~20			V/mA	Remote Speed Control signal
Digital Control Signal	24			V	Switching Signal
Adjustment Method	6			Button	
Standby Power Consumption	—	5	—	W	
Display Method	5			Digit	LED
Ambient Temperature	0	25	40	°C	No Condensation
Ambient Humidity	10	60	85	%	
Storage Ambient Temperature	-20	25	85	°C	

Appendix C: Troubleshooting Suggestions and Error Explanations

Fault Phenomenon		Troubleshooting Suggestions
1	No display on LED screen after power on startup	<ul style="list-style-type: none"> ● Make sure the Input Power is live. ● Make sure the Input Power Cable is properly connected.
2	LED screen displays normally but vibratory feeder has no output or sound	<ul style="list-style-type: none"> ● Make sure the Output Power Cable is properly connected. ● Make sure Output Voltage is not below 85V. ● Make sure the controller is not stopped by the ON/OFF button when the Stop Indicator is on. ● Make sure the controller is not stopped by the ON/OFF control signal when the Stop Indicator is on. ● Make sure the controller is not stopped by parameters f 2, f 3 or f 4 setting when the Stop Indicator is on. ● Reset the controller.
3	ON/OFF Control does not work	<ul style="list-style-type: none"> ● Make sure ON/OFF Control Signal is correctly connected to the controller. ● Make sure parameter f 2, f 3, and f 4 are set correctly as you control expectation. ● Reset the controller.
4	Cross-Talk	<ul style="list-style-type: none"> ● Connect Sync Signal Wire between the controllers and set the Slave Controller to Sync Mode
5	LED screen displays normally, sounds can be heard from the vibratory feeder but no output	<ul style="list-style-type: none"> ● Make sure Output Frequency is not far away from resonant frequency of the vibratory feeder ● Reset the controller
6	LED screen displays 	Short-Circuit Protection <ul style="list-style-type: none"> ● Make sure the Output Power Cable and the vibrator electromagnet are not short circuited ● Disconnect the Output Power Cable from the controller and turn on the power switch again. If Err01 is still displayed on the LED screen, contact us for repair
7	LED screen displays 	Overcurrent Protection <ul style="list-style-type: none"> ● Reduce Output Voltage of the controller ● Make sure armature gap of the vibrator electromagnet is not too big
8	LED screen displays 	Overheat Protection <ul style="list-style-type: none"> ● Place the controller in a well ventilated environment
9	LED screen displays 	<ul style="list-style-type: none"> ● Reserved, contact us for repair
10	LED screen displays 	<ul style="list-style-type: none"> ● Internal Communication abnormal, contact us for repair

Fault Phenomenon		Troubleshooting Suggestions
11	LED screen displays 	<ul style="list-style-type: none"> ● Temperature sensor abnormal, contact us for repair
12	LED screen displays 	<ul style="list-style-type: none"> ● Reserved, contact us for repair
13	LED screen displays 	<ul style="list-style-type: none"> ● Sync Signal Error, contact us for repair
14	LED screen displays 	<ul style="list-style-type: none"> ● Vibration Sensor Type Error The type of vibration sensor connected to the controller is mismatched with the "vibration sensor type 1" parameter set in the controller.

Appendix D: Controller Reset

Step 1: Press and hold “FUNC” and ▲ buttons for 2 seconds to enter Advanced Parameter Adjustment Status.

Step 2: Press “FUNC” button repeatedly until you have 88888 parameter flashing on LED screen.

Step3: Press ▲ button and hold until - - - - - is displayed on the LED screen.

Step 4: Release ▲ button to finish the Controller Reset process, U150 is displayed on the LED screen.



Bryant Control, Inc.

www.bryantcontrol.com

Tel: 317-542-8154

Fax: 317-542-8154

E-mail: jhenz@bryantcontrol.com

Address: 9925 E 126th St. Suite 130 Fishers, IN 46038