

DC300 - Data Sheet

DC SENSOR TIMING BOARD (NPN OR PNP INPUT)

APPLICATIONS FOR THE DC300 BOARD

1. WHEN USING A COMPATIBLE SENSOR AND BOTH ON DELAY AND OFF DELAY FUNCTIONS ARE REQUIRED
2. WHEN USING A COMPATIBLE SENSOR AND A ONE-SHOT TIMER IS REQUIRED
3. WHEN USING A SENSOR THAT REQUIRES MORE THAN 30mA OF POWER (MAXIMUM 120mA)
4. WHEN OUTPUT REQUIREMENTS ARE THREE SEPARATE LOAD CIRCUITS

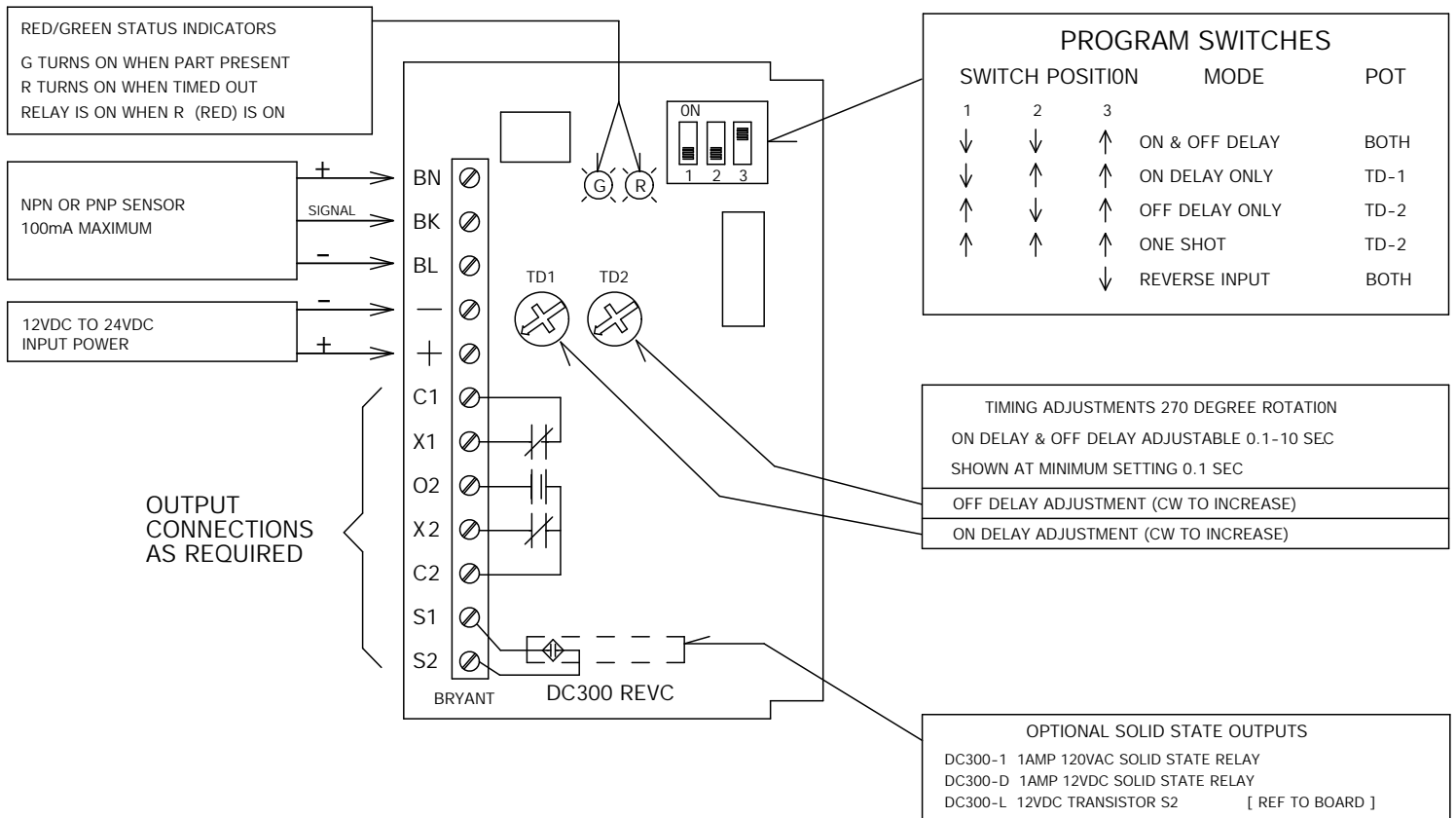

NOTES:

REV C Change-Silkscreen change for terminal designations.
 Changed O1,O2,X2 to O2,X2,C2 to correctly designate the relay outputs