

MF Type Service Kits, 115 Volt AC

PARTS LIST:

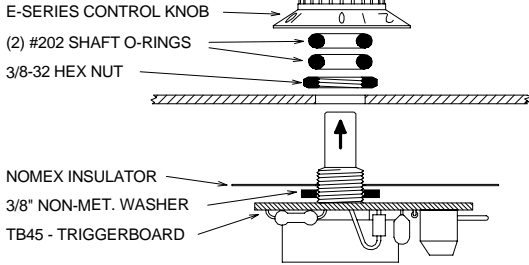

ALSO INCLUDED IN THE MFC150K SERVICE KIT:
 (1) TC22 - 15A/400V TRIAC ASSY. (1) TRIGGERBOARD CABLE ASSY.

MFC150K



MFC150K SERVICE KIT

10AMP OR LESS/115VAC, 50/60Hz

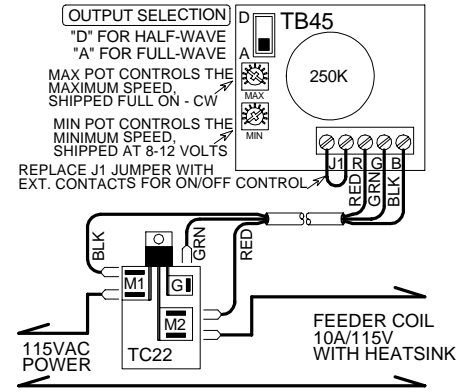

PARTS LIST:

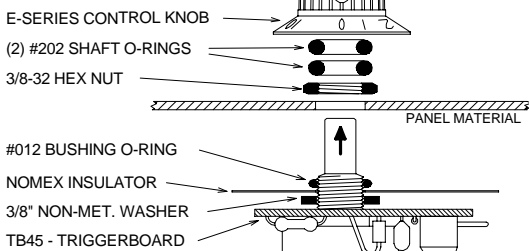

ALSO INCLUDED IN THE MFC250GK SERVICE KIT:
 (1) Q6025P - 25A/600V TRIAC (1) TRIGGERBOARD CABLE ASSY.
 (2) 1/4" PIGGYBACK CONNECTOR

MFC250GK



MFC250GK SERVICE KIT

20AMP OR LESS/115VAC, 50/60Hz

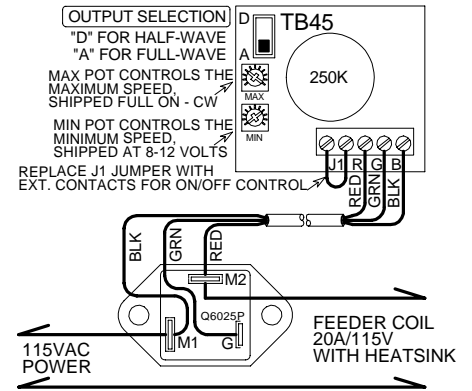

MF Type Service Kits, 230 Volt AC

PARTS LIST:

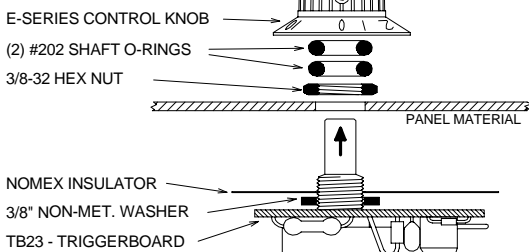

ALSO INCLUDED IN THE MFC152K SERVICE KIT:
 (1) TC22 - 15A/400V TRIAC ASSY. (1) TRIGGERBOARD CABLE ASSY.

MFC152K



MFC152K SERVICE KIT

10AMP OR LESS/230VAC, 50/60Hz

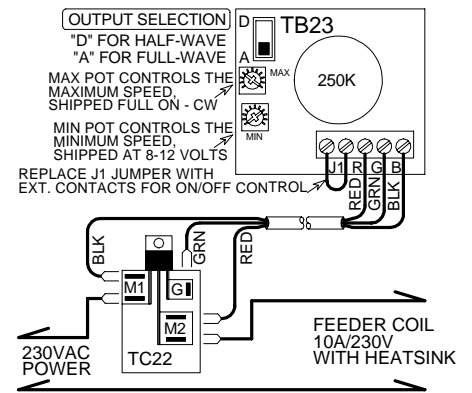

PARTS LIST:

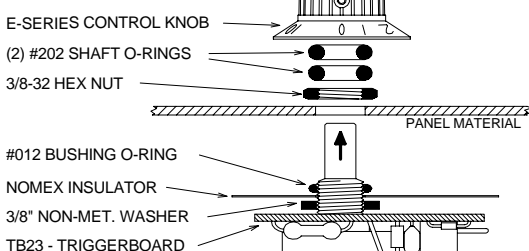

ALSO INCLUDED IN THE MFC252GK SERVICE KIT:
 (1) Q6025P - 25A/600V TRIAC (1) TRIGGERBOARD CABLE ASSY.
 (2) 1/4" PIGGYBACK CONNECTOR

MFC252GK



MFC252GK SERVICE KIT

20AMP OR LESS/230VAC, 50/60Hz

