

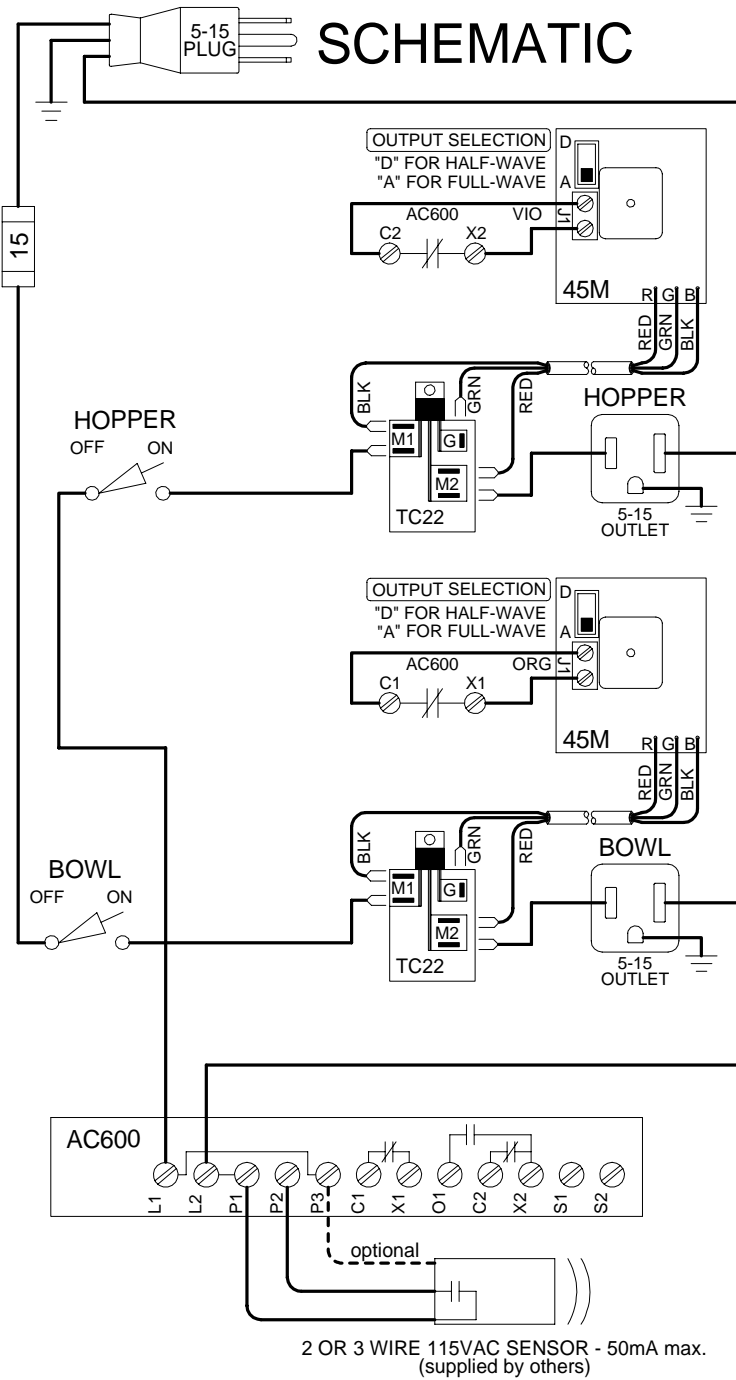

SCHEMATIC



MODEL# ED15600 BH		11-9-04 REV: A
15AMP / 115VAC, 50/60Hz		MH6 ENCLOSURE (NEMA 1)
ITEM DESCRIPTION	SERVICE PART #	
BOWL CONTROL	C150 (includes 45M and TC22)	
HOPPER CONTROL	C150 (includes 45M and TC22)	
INPUT-TIMING-OUTPUT BOARD	AC600	
2 OR 3 WIRE SENSOR - 50mA max.	(supplied by others)	
NOTES: Bowl switch shuts off both bowl and hopper. Full-track sensor shuts off bowl and hopper.		

